



US005797563A

United States Patent [19]

[11] Patent Number: **5,797,563**

Blackburn et al.

[45] Date of Patent: ***Aug. 25, 1998**

[54] SYSTEM FOR INCREASING THE AERODYNAMIC AND HYDRODYNAMIC EFFICIENCY OF A VEHICLE IN MOTION

[76] Inventors: **Ronald F. Blackburn**, 9546 S. Harford Ct., Highlands Ranch, Colo. 80126; **Barry M. Warmkessel**, 767 Chopin Dr., Sunnyvale, Calif. 94087; **Sonja M. Kawamoto**, 6850 Glenview Dr., San Jose, Calif. 95120

3,095,163	6/1963	Hill	244/205
3,162,398	12/1964	Clauser et al.	244/205
3,219,851	11/1965	Kidwell	322/2 R
3,224,375	12/1965	Hoff	244/130
3,360,220	12/1967	Meyer	244/205
3,448,791	6/1969	Clark	244/158
4,320,300	3/1982	Mariella .	

Primary Examiner—Andres Kashnikov
Assistant Examiner—Tien Dinh
Attorney, Agent, or Firm—Chris Papageorge

[*] Notice: The term of this patent shall not extend beyond the expiration date of Pat. No. 5,791,599.

[21] Appl. No.: **625,914**

[22] Filed: **Apr. 1, 1996**

Related U.S. Application Data

[63] Continuation-in-part of Ser. No. 504,056, Jul. 18, 1995.

[51] Int. Cl.⁶ **B64C 1/38**

[52] U.S. Cl. **244/130; 322/2 A; 244/204; 244/205**

[58] Field of Search 244/158 R, 130, 244/134 R, 134 D, 204, 205, 158 A, 163, 160; 60/39.07; 219/764, 748, 749; 322/2 A, 2 R

[56] References Cited

U.S. PATENT DOCUMENTS

2,102,527	12/1937	Hadley	244/205
2,946,541	7/1960	Boyd	244/205

[57] ABSTRACT

The system includes radiation generation and transmission components which radiate tuned microwave electromagnetic energy outwardly from a vehicle through an antenna into a fluid medium through which the vehicle is moving. The microwave radiation is at the frequency of harmonic resonance electromagnetic excitation of the molecules of the medium which produces efficient heating and ionizing of the fluid resulting in a reduction of the mass density thereof. This reduction decreases the drag forces acting on the vehicle resulting in a greatly enhanced aerodynamic and/or hydrodynamic efficiency and also decreases the intensity of the shock waves (which often lead to sonic booms). An aircraft's dramatically higher speed in the surrounding rarefied medium can make it appear to be travelling at "supersonic" speeds. The system also includes a set of coiled wires and magnetic plates producing magnetic fields proximal to the vehicle and oriented to deflect heated molecules (ionized by the microwave heating) away from the vehicle thereby preventing or reducing contact of the heated molecules with the vehicle's outer surfaces and heating thereof.

29 Claims, 14 Drawing Sheets

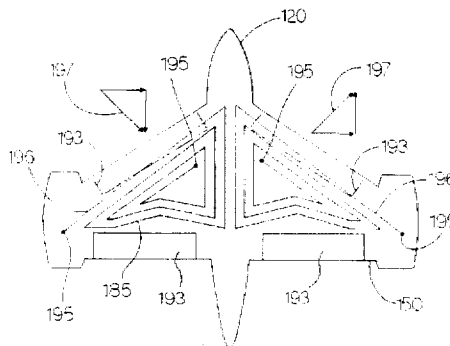
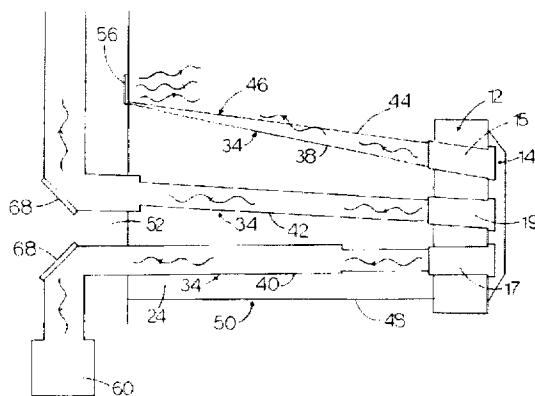

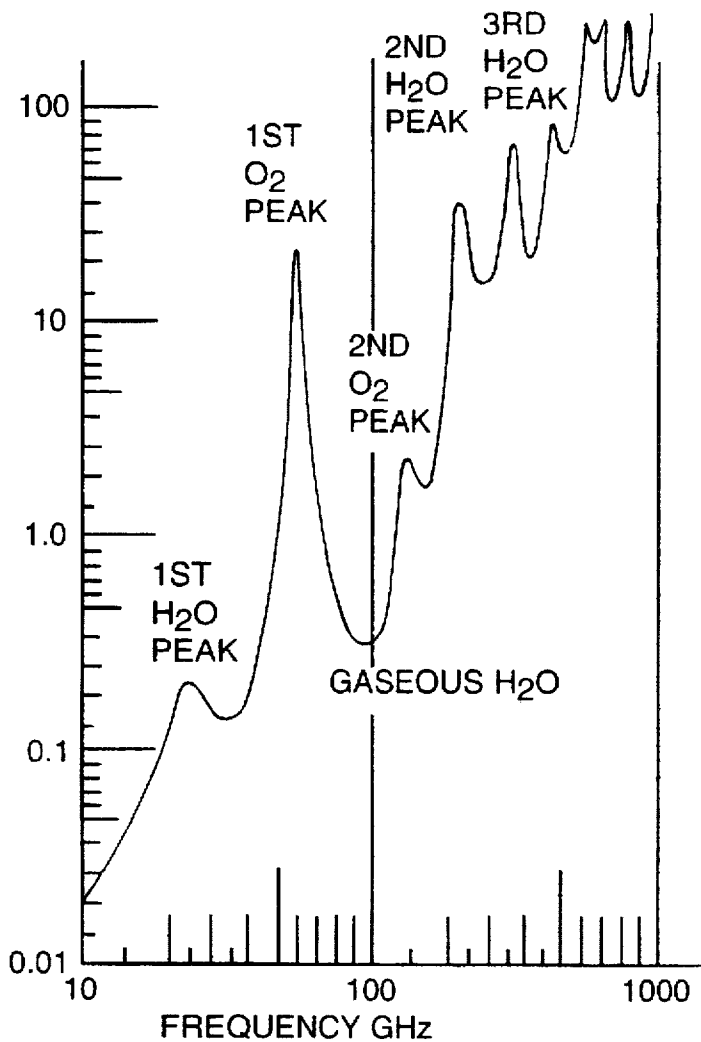

FIG. 1

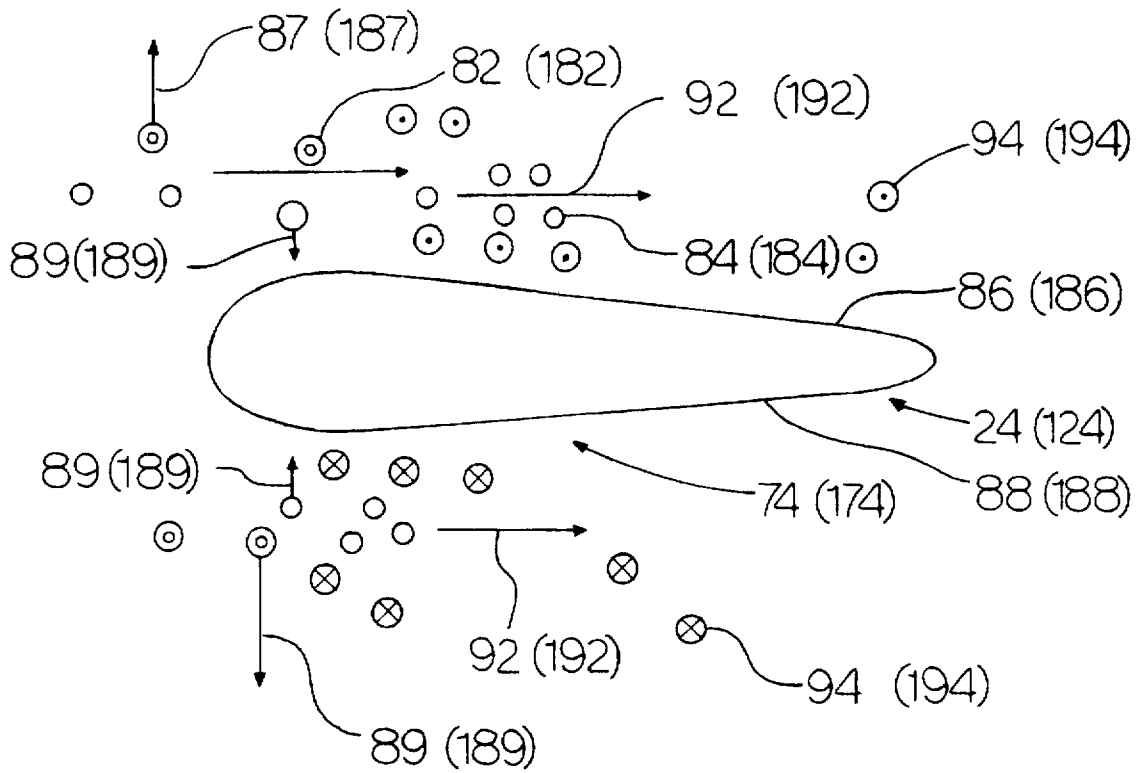
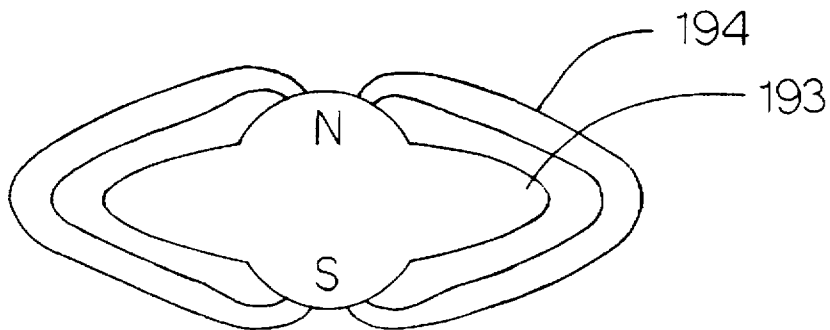

FIG. 2

FIG. 3



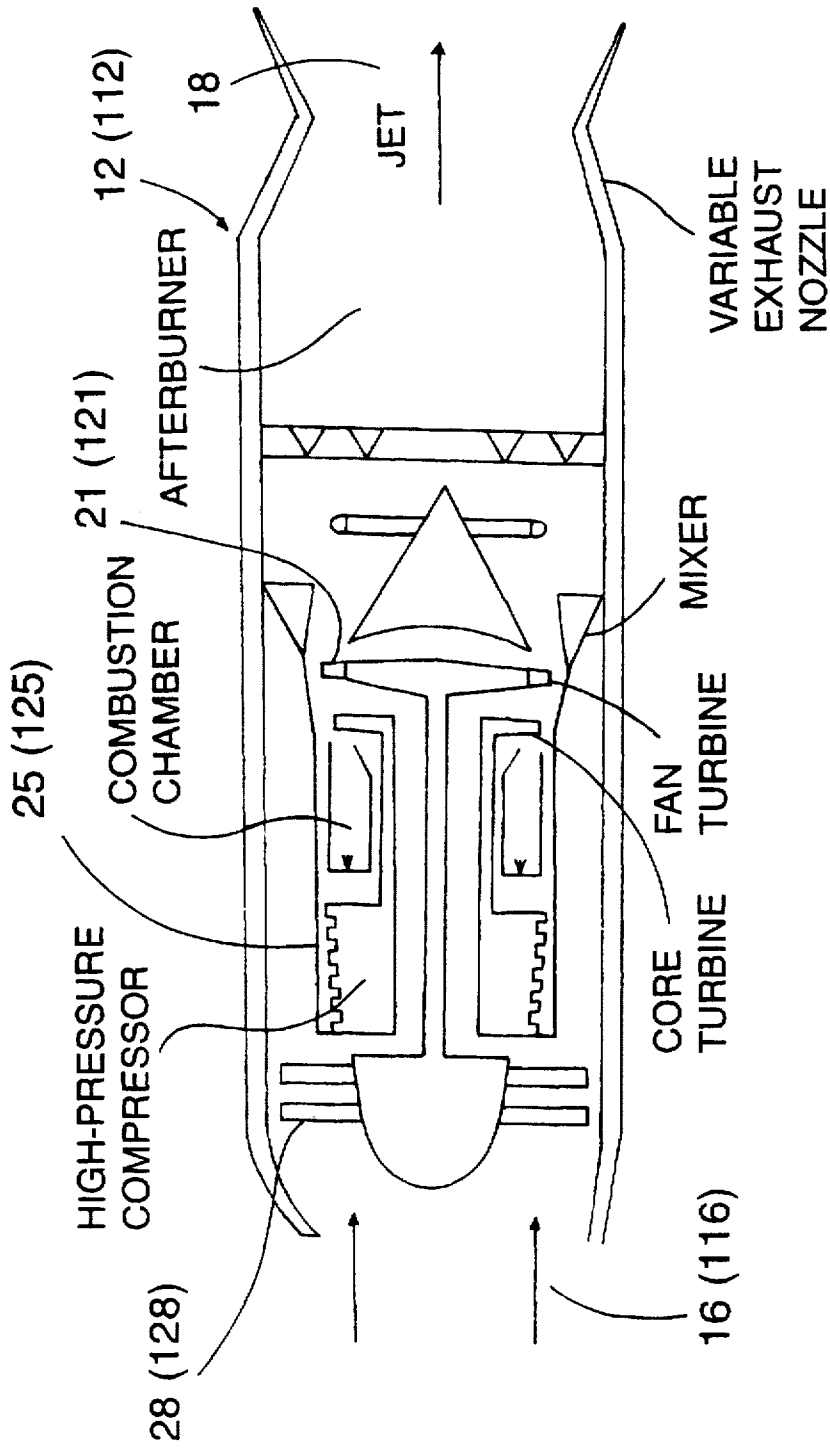

FIG. 4

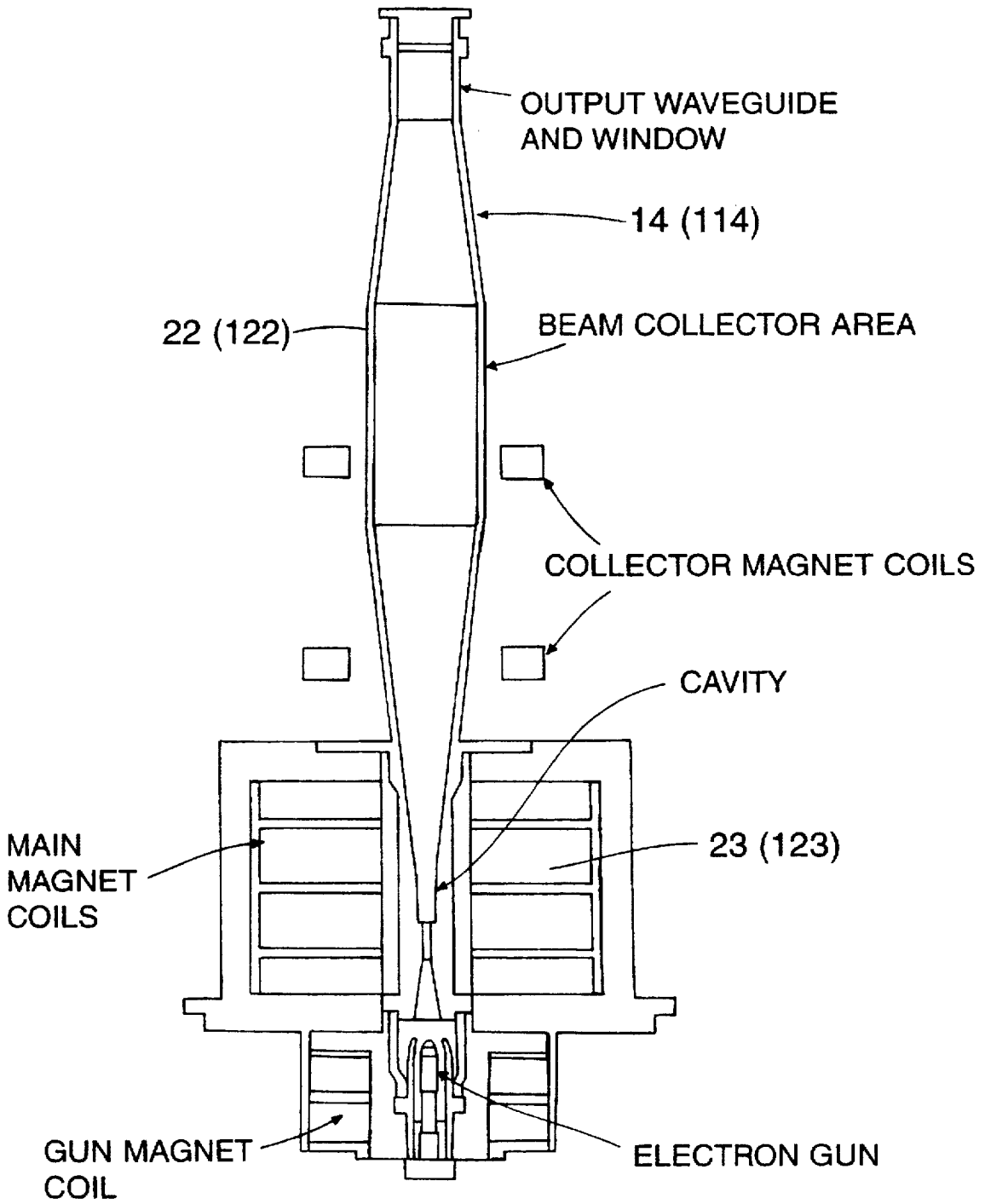

FIG. 5

FIG. 6

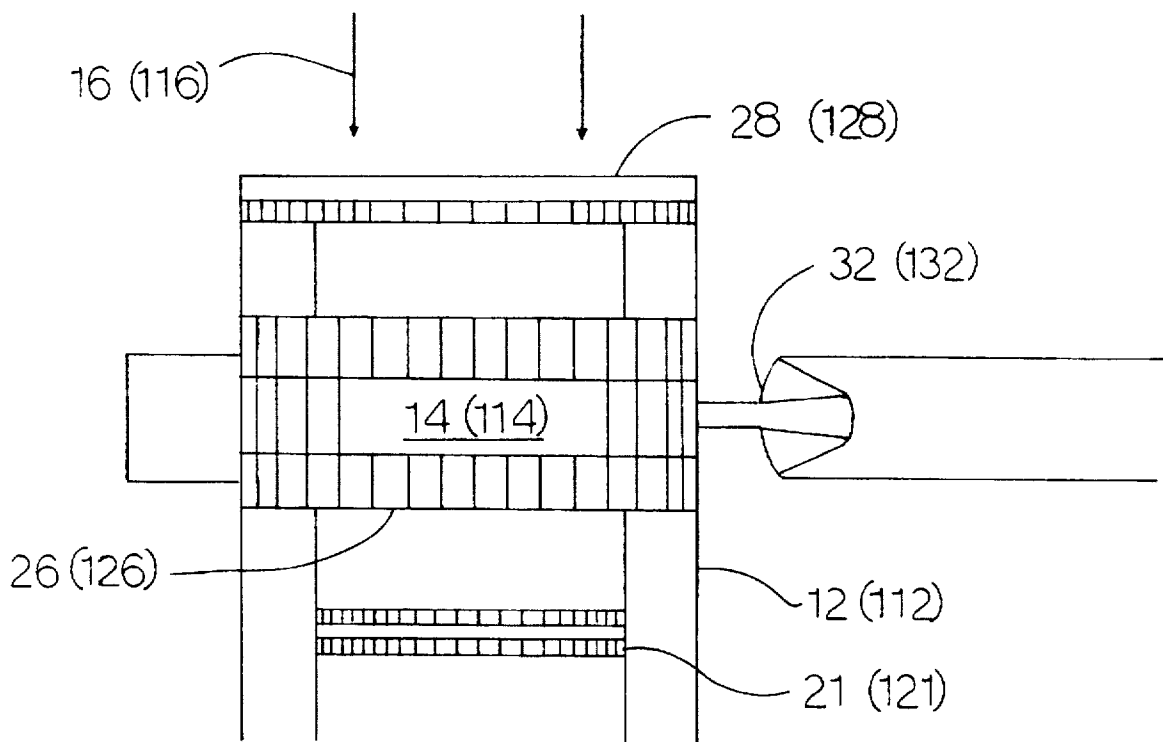
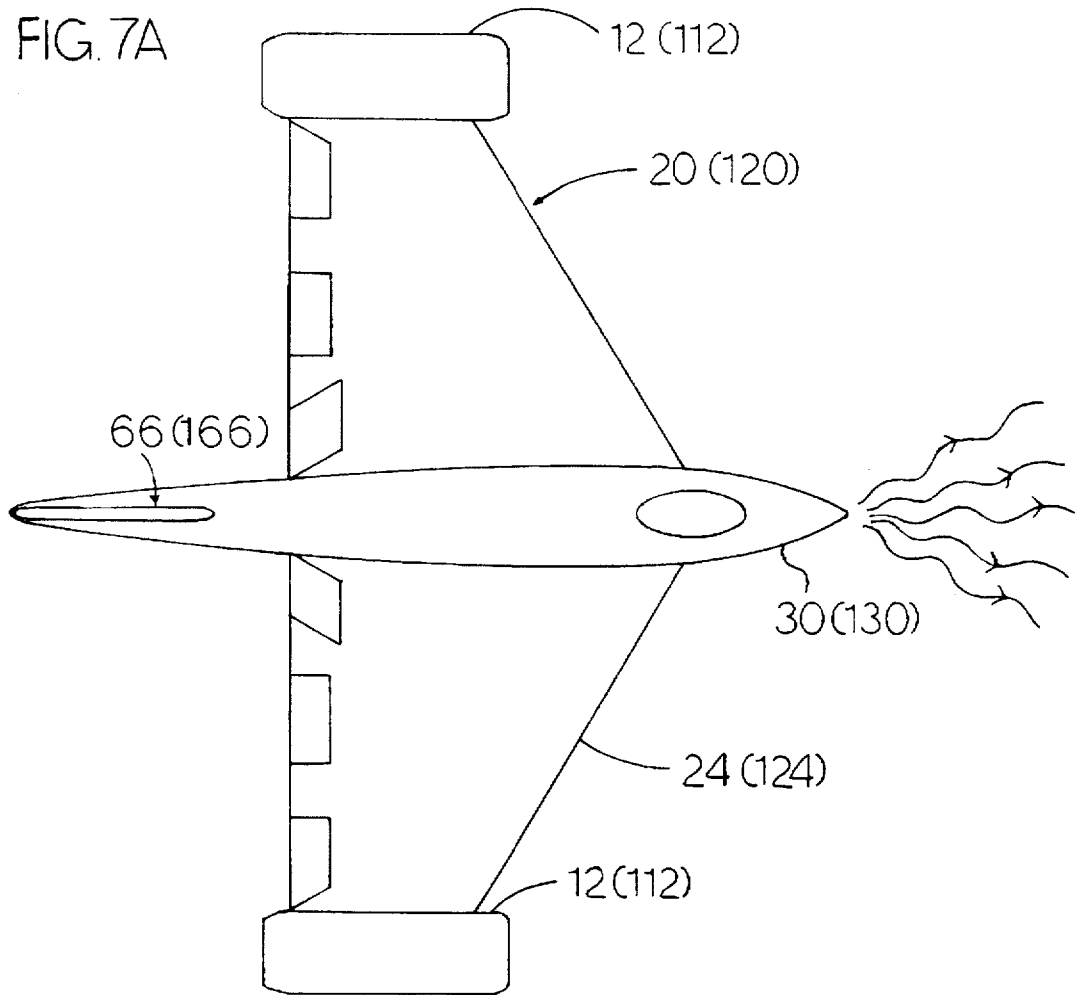
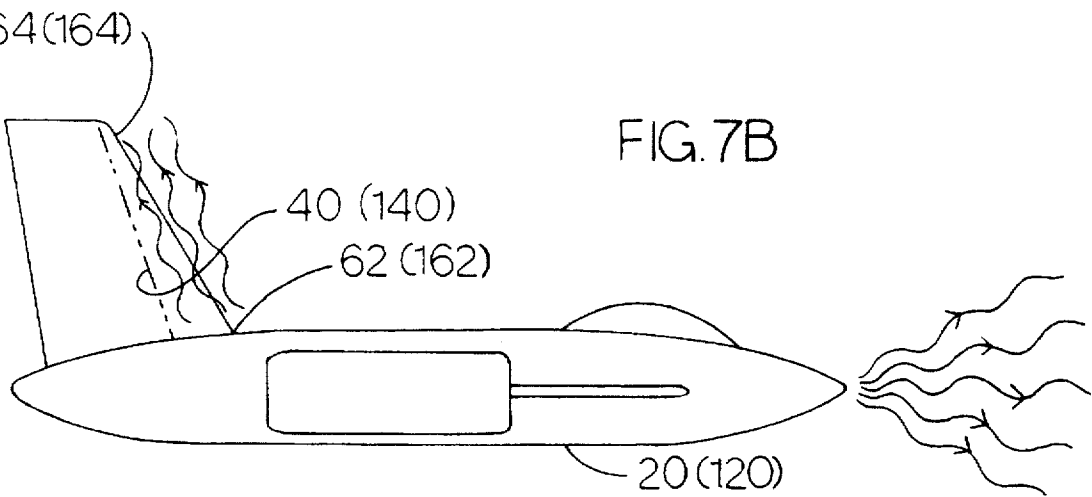

FIG. 7A



64 (164)

FIG. 7B



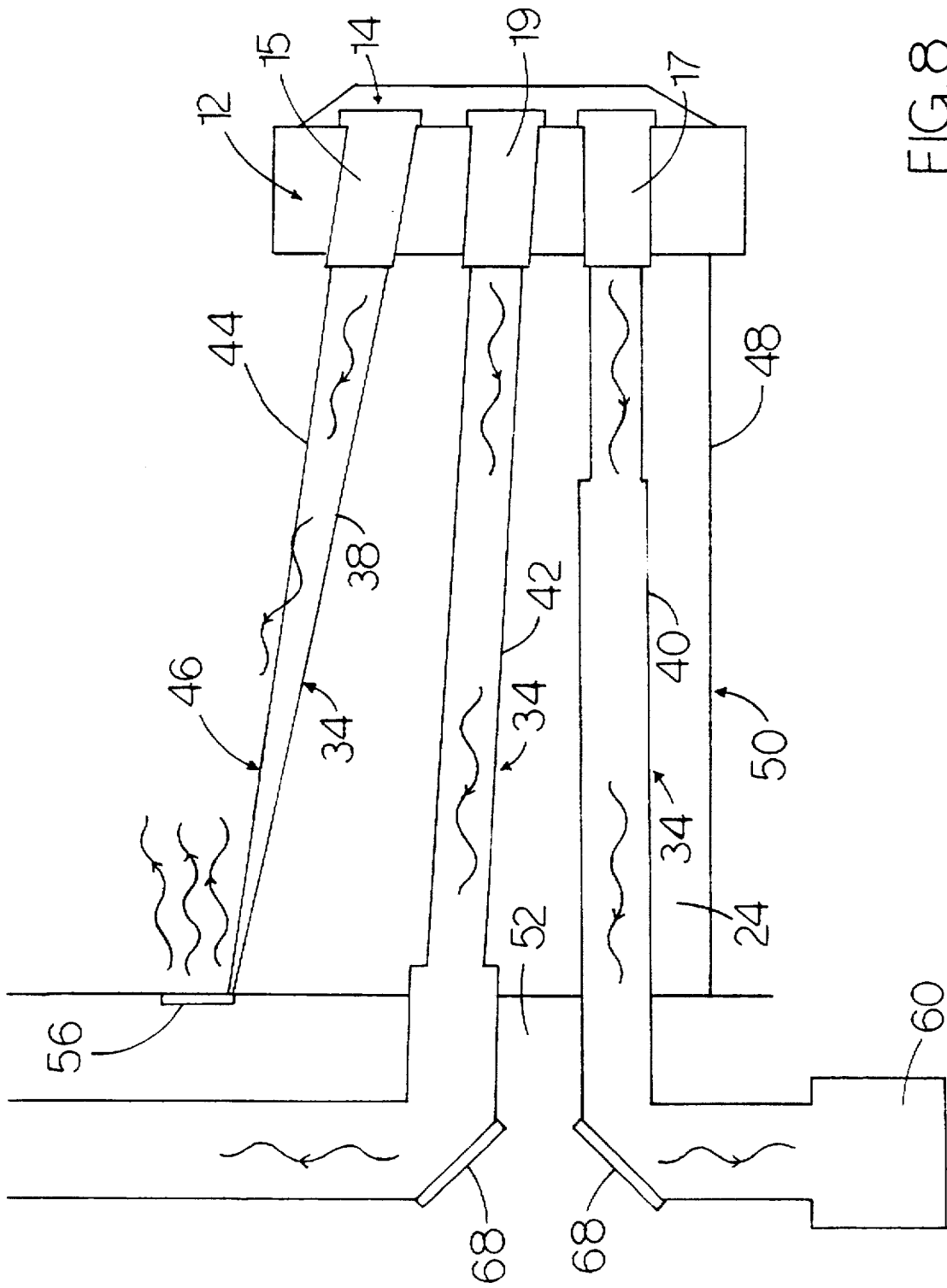

FIG. 8

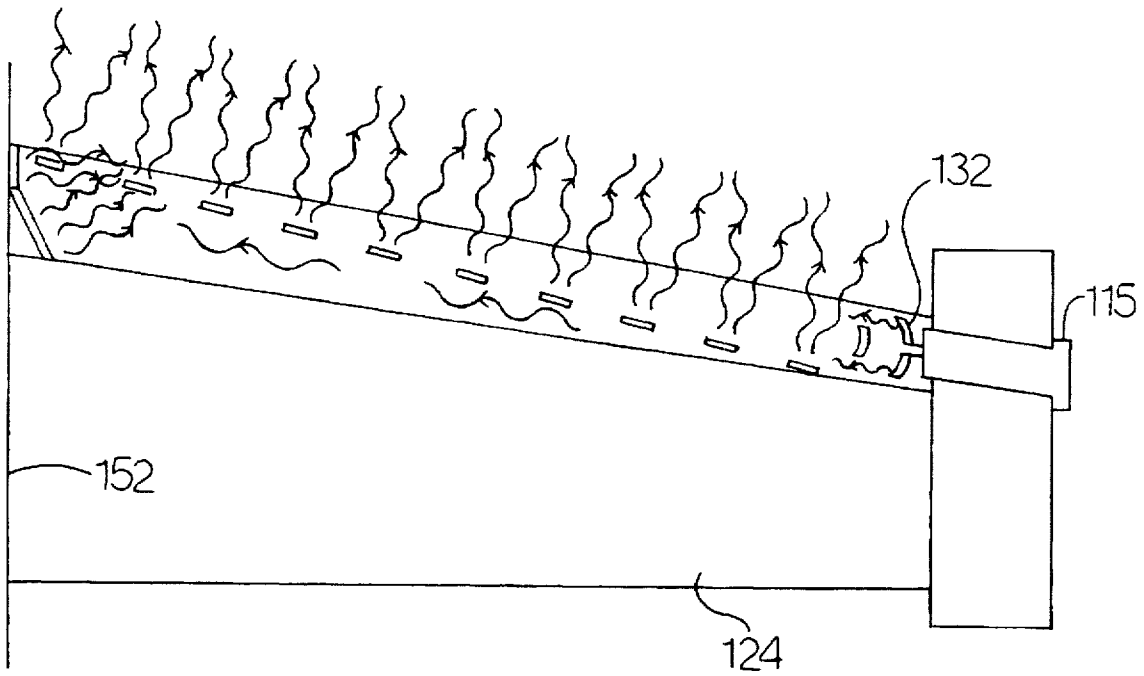
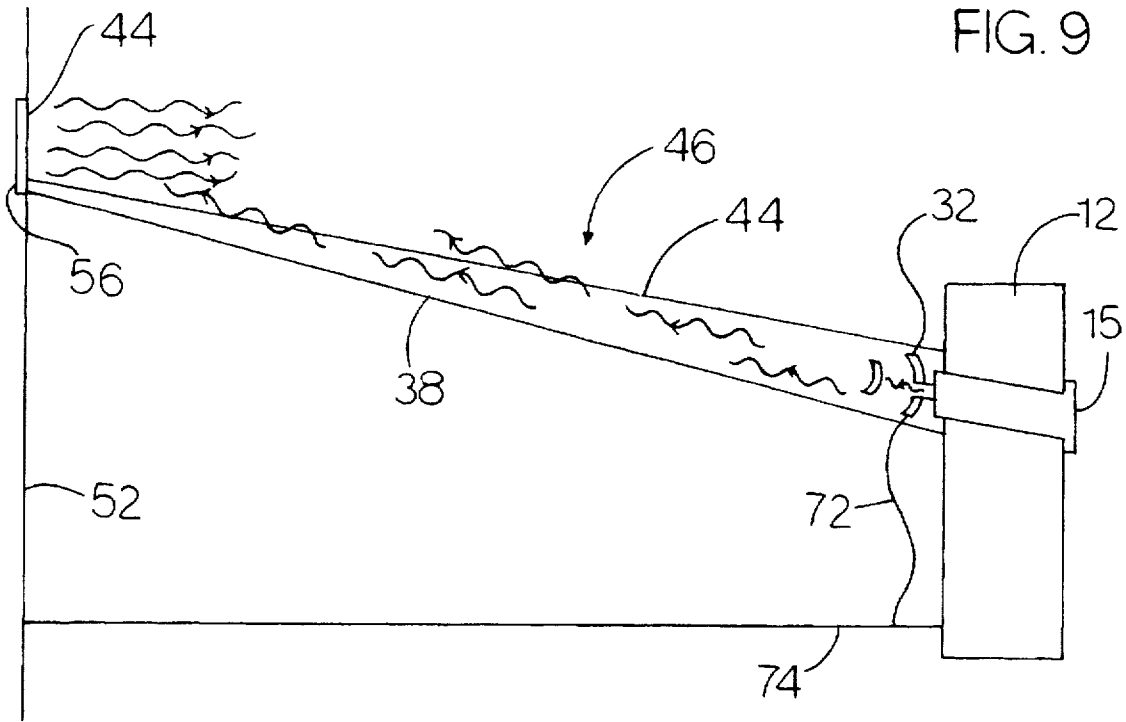

FIG. 15

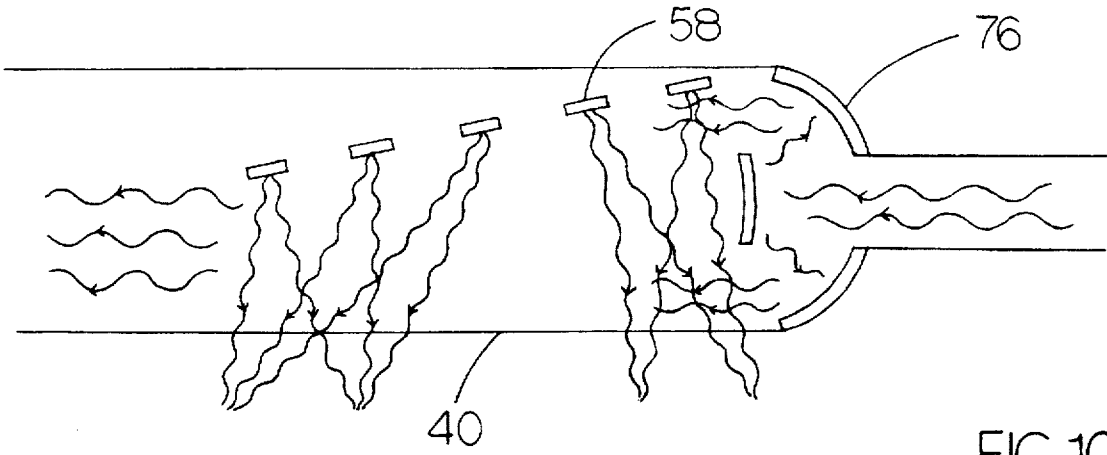

FIG. 10

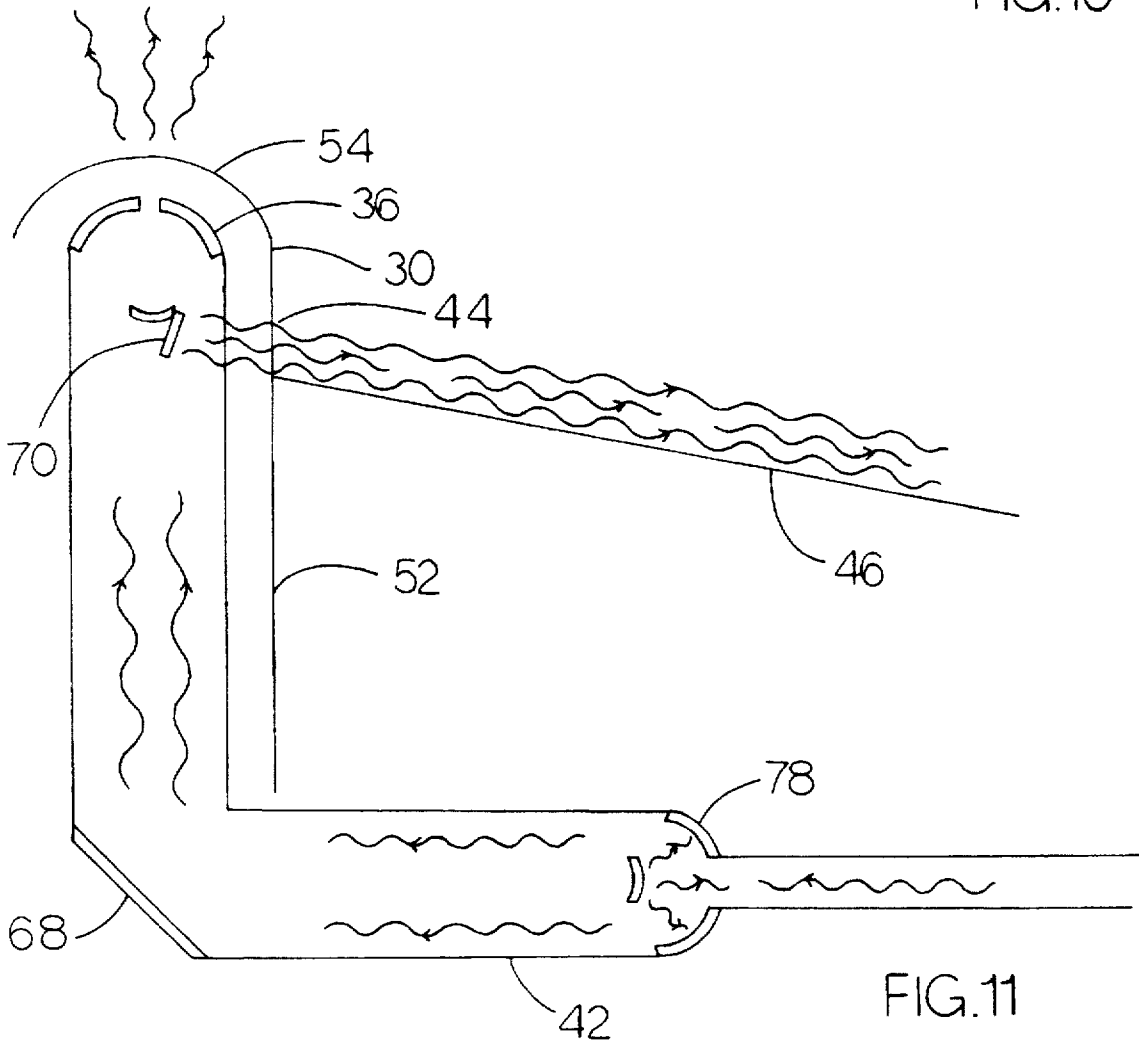

FIG. 11

FIG. 12

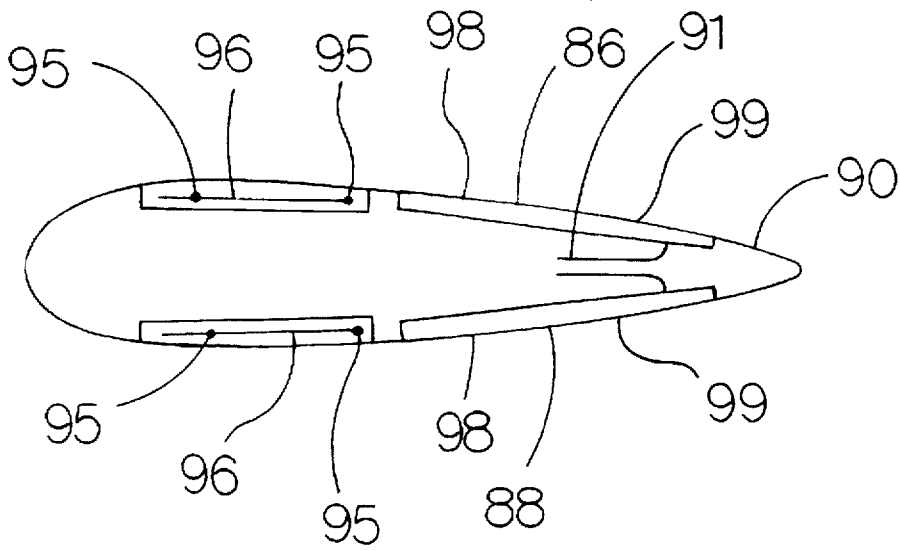
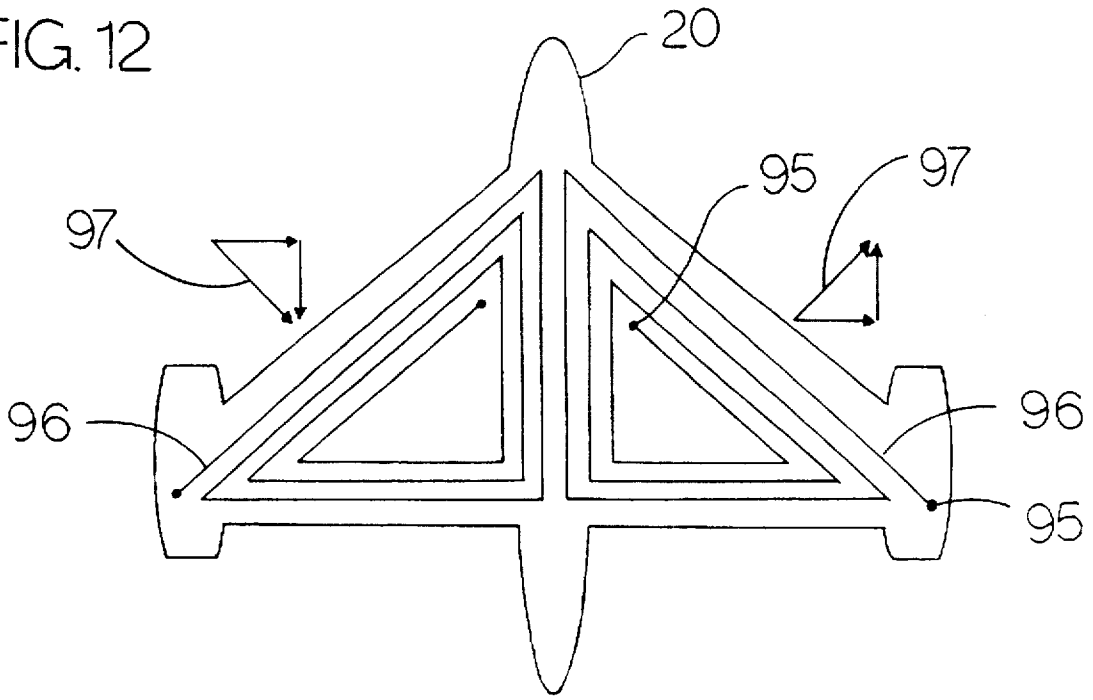

FIG. 13

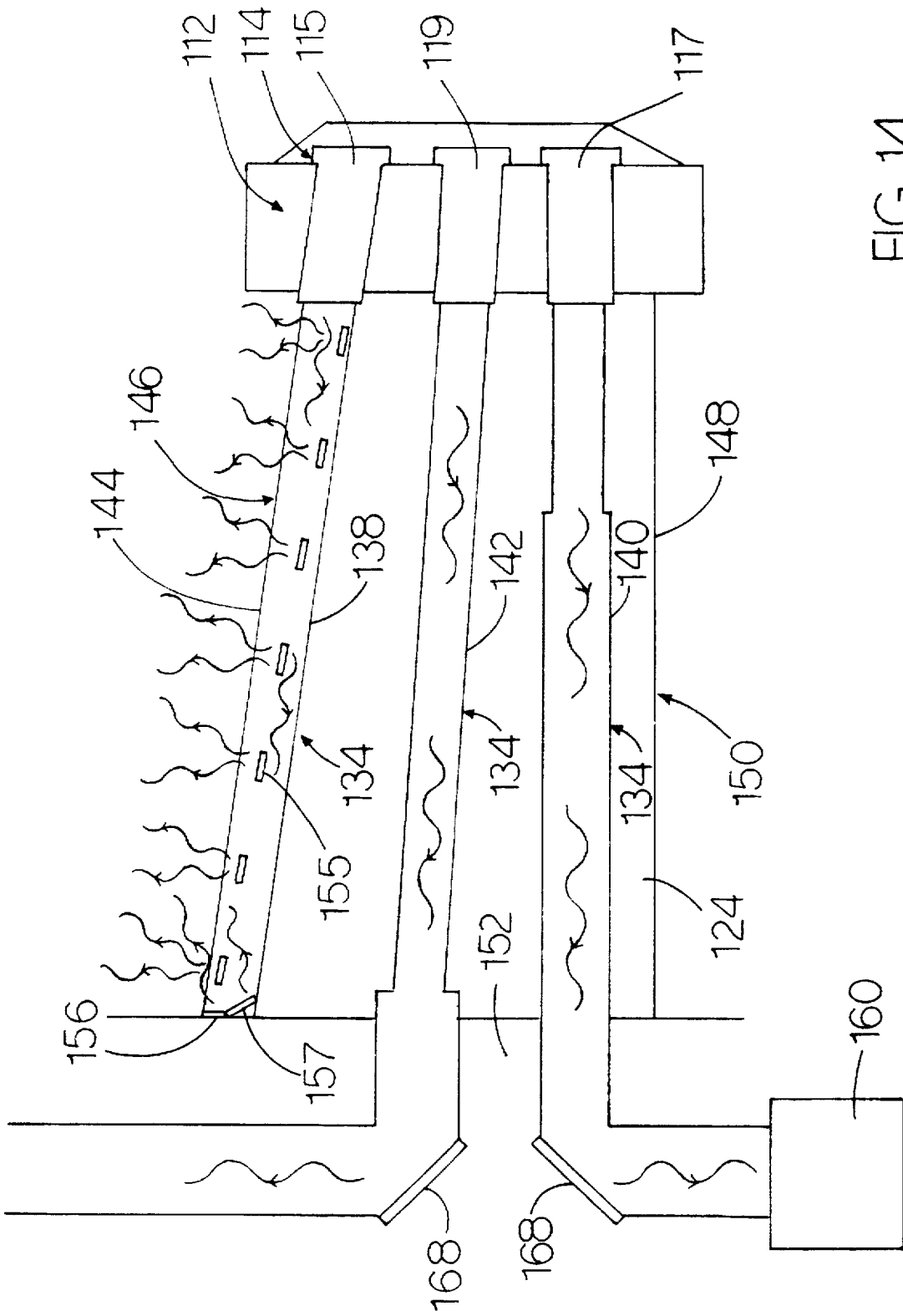

FIG. 14

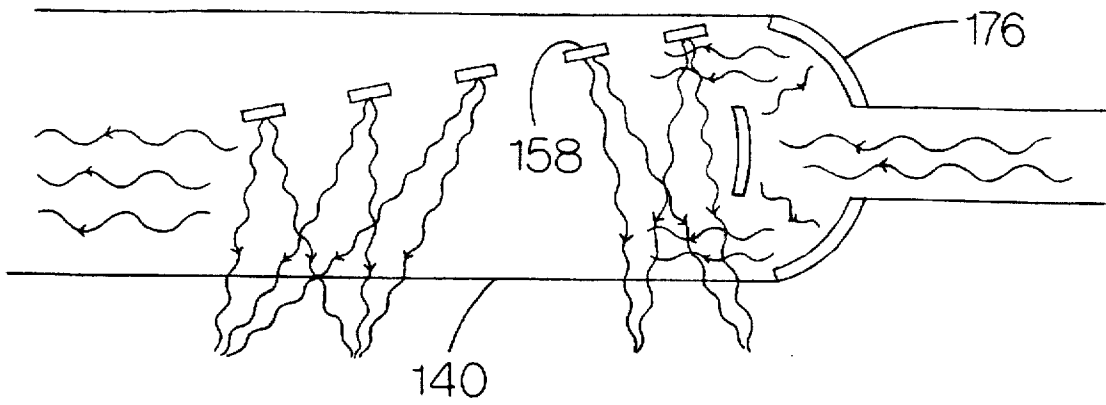

FIG. 16

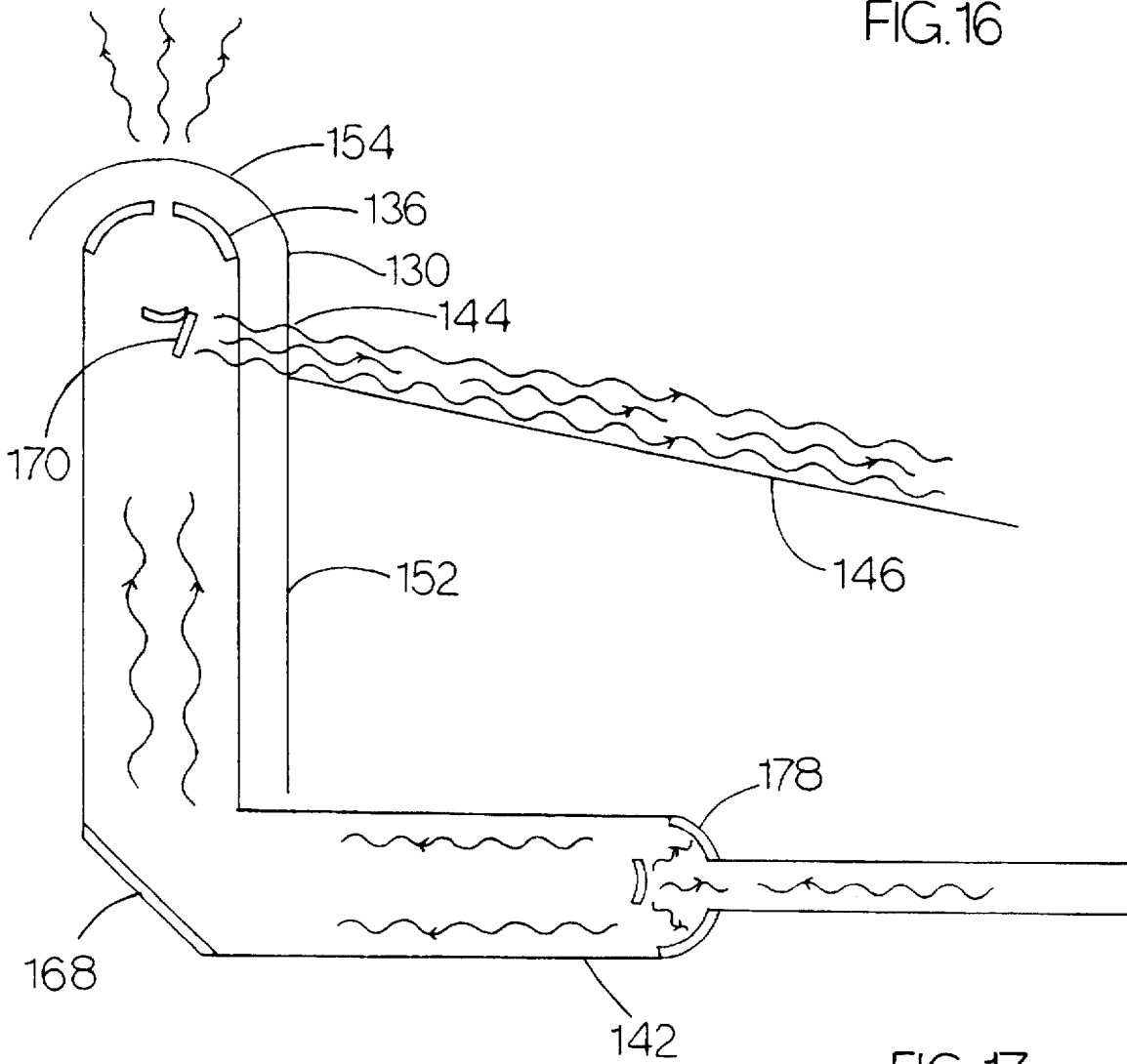

FIG. 17

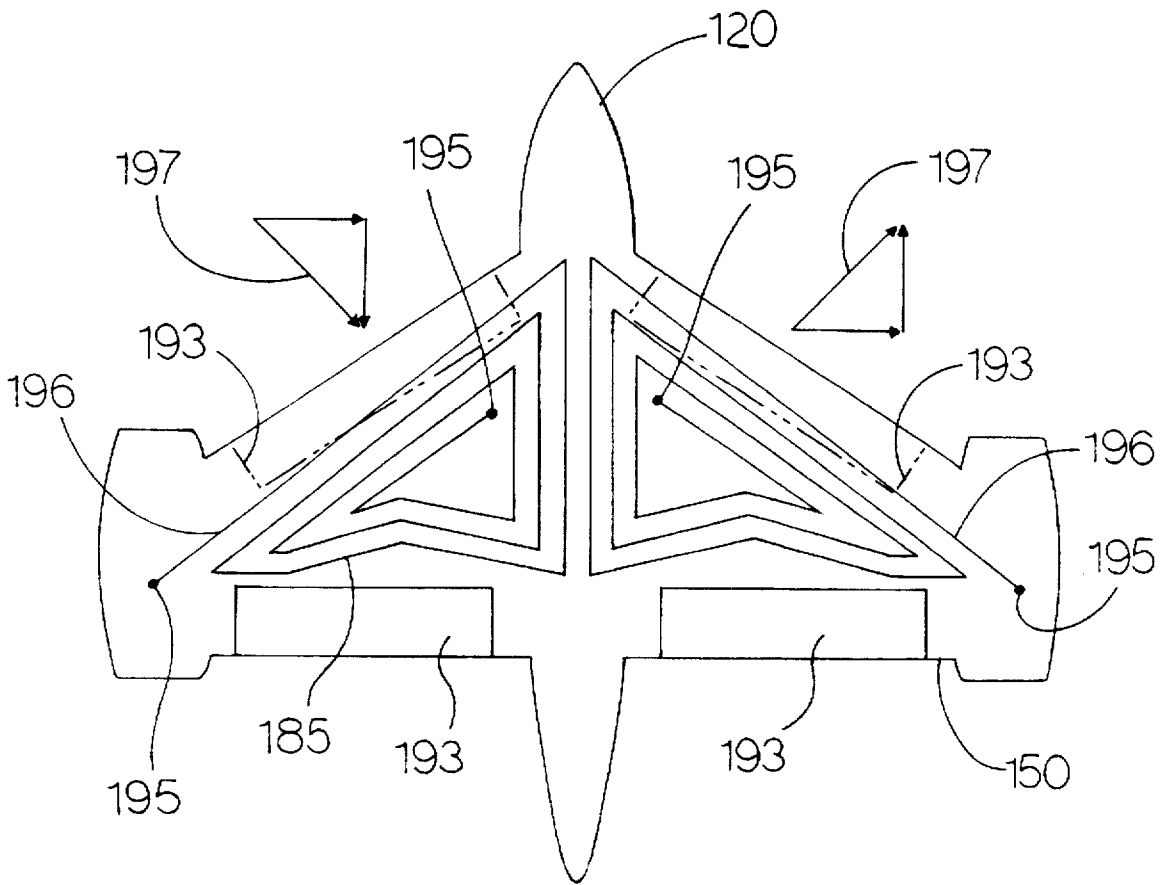

FIG. 18

**SYSTEM FOR INCREASING THE
AERODYNAMIC AND HYDRODYNAMIC
EFFICIENCY OF A VEHICLE IN MOTION**

This application is a continuation-in-part of patent application Ser. No. 08/504,056 entitled "A System for Increasing the Aerodynamic and Hydrodynamic Efficiency of a Vehicle in Motion" filed Jul. 18, 1995 by applicants herein, Ronald F. Blackburn and Barry M. Warmkessel.

BACKGROUND OF THE INVENTION

The invention relates generally to systems for facilitating the motion of a vehicle through a fluid medium and, more particularly, to systems for facilitating the motion of aircraft through the atmosphere in order to significantly reduce the amount of energy required to propel the aircraft, significantly increase the maximum speed of the aircraft and substantially reduce the intensity and incidence of shock waves associated with the motion.

The well known sonic boom is a significant problem presented by aircraft capable of flying at supersonic speeds. The sonic boom is so annoying and so often damaging to homes, buildings and other property that military aircraft have been required to attain supersonic speeds over large bodies of water or sparsely populated areas in order to minimize these undesired effects. With the increasing prevalence and viability of commercial supersonic flight resulting from government research and development efforts and the increasing viability of commercial aircraft designed for speeds well in excess of supersonic speeds, the sonic boom effects have become more problematic.

The sonic waves generated by supersonic flight are also detrimental to the practicality of such supersonic flight because they result in an aerodynamic drag effect which retards the velocity of the aircraft thereby requiring more energy to propel it. For this reason and because frictional forces resisting movement of an aircraft increase with the square of the aircraft's velocity, high velocity aircraft as well as other types of high velocity vehicles typically entail higher fuel expenditures and concomitantly produce higher levels of pollution as well as high consumption of fuel often made from nonrenewable natural resources. This high pollution and high fuel consumption is a serious economic and environmental problem. Solutions to this problem have been sought by designing engines that have higher fuel efficiencies and lower pollutant emissions. These design efforts have successfully produced engines that are very efficient. Unfortunately, the proliferation of motorized vehicles of many sorts has nevertheless resulted in an increase in global pollution and higher energy consumption. In addition, the pollution reduction and energy efficiency augmentation systems for conventional engines have become so effective that further improvements on systems used on conventional engines is not likely to produce substantial improvements. Consequently, many engineers have sought to reduce pollution and increase the energy efficiency of conventional vehicles by seeking to make modifications in other areas.

Ships and submarines are notoriously slow moving. Increases in the cruising speeds of surface ships are prohibitively expensive to attain, and this is the reason most commercial shipping operates at a relatively slow speed of approximately twenty knots. Submarines, lacking the bow wave common to surface ships can travel faster, but substantial power sources are needed for a modest advantage over the speeds of surface ships. What's worse, there is tremendous acoustical vibration associated with these high

speeds, which causes the submarine to lose its stealthy advantage normally afforded by the ocean's depths. Torpedoes can move faster than submarines, but they consume tremendous amounts of the limited non-nuclear fuels available along with the disadvantage of the accompanying warning from their acoustical signature that the weapon has been fired.

Many have sought solutions to the aerodynamic applications of these problems by developing systems which reduce the mass density of the medium through which a vehicle is moving and thereby reduce the drag forces acting on the vehicle while it is in motion. Some of these systems have specifically sought to reduce the mass density of the atmosphere through which aircraft are traveling and thereby reduce aerodynamic drag acting on the aircraft. This desired goal would not only provide increased fuel efficiency but also enable the aircraft to achieve higher maximum attainable speeds. As an additional benefit, the intensity and incidence of shock waves associated with the aircraft would be reduced resulting in elimination of or reduction of the intensity of a sonic boom otherwise produced when the aircraft attains supersonic speeds.

Some prior art methods and devices for reducing the mass density of the atmosphere through which an aircraft is flying have utilized incendiary compounds to heat the air and thereby reduce the mass density thereof. Two examples of such methods are disclosed in U.S. Pat. No. 4,917,335 to Tidman and U.S. Pat. No. 3,620,484 to Schoppe. The Tidman method essentially generates and maintains combustion of a flammable compound which is ejected from the aircraft directly into the atmosphere immediately in front of the aircraft. The Schoppe method utilizes a mechanical flame thrower to also produce combustion directly in front of the aircraft but additionally uses a blunt nosed body to compress the air prior to the combustion for enhanced efficiency thereof. Thus, in both of these methods, the aircraft consequently travels through a fireball of reduced mass density which reduces aerodynamic drag and the incidence and severity of sonic boom. However, a primary disadvantage of such methods is that the chemical reaction as well as the ejection of the combustible mass may not be fast enough to rarefy the atmosphere in front of an aircraft traveling at supersonic speeds. Another important disadvantage of such methods is that the fireball through which the aircraft is moving transfers a substantial amount of heat directly to the aircraft surfaces resulting in excessive heating of the aircraft; this undesired heating of the aircraft can result in melting, weakening, failure or malfunction under stress of structural components as well as of electronic or other heat sensitive components of the aircraft. In addition, the required speed of combustion may result in generally incomplete combustion and thereby wasting of fuel and production of inordinate amounts of pollutants. Moreover, the requirement of a blunt body precludes the Schoppe system from being used to reduce the density of the atmosphere in front of the entire aircraft or, more specifically, in front of wing leading edges as well as other portions thereof.

Other prior art systems designed to reduce aerodynamic drag and sonic waves rarefy the atmosphere in front of the aircraft by moving air molecules rearwardly from the leading edges of the aircraft. An example of such a system is disclosed in U.S. Pat. No. 3,446,464 to Donald. The Donald apparatus utilizes electrodes placed both at the leading edges and rearward of the leading edges. Different electrical potentials applied to the electrodes produce an electrical field which moves the air molecules rearwardly from the leading edges thereby reducing the buildup of air pressure in front of

the leading edges. However, a primary shortcoming of the Donald apparatus is that it does not directly move air molecules which are in front of the leading edges and thus is of limited effectiveness in reducing aerodynamic drag and sonic boom.

Since the 1940's some designers of aircraft have sought to reduce aerodynamic drag by radioactive excitation of the air molecules proximal to or adjacent to the aircraft. Early designs have utilized radioactive coatings on the skins of the aircraft to ionize the air molecules at the boundary layer at the aircraft fluid-solid interface thereby inducing repelling or attractive forces on these ions and/or to induce a vibrational or rotational excited state in the air molecules thereby altering their viscosity. A technologically improved design utilizing such a concept is disclosed in U.S. Pat. No. 3,510,094 to Clark in which the magnitude and number of alpha and beta particle emissions from the radioactive layer on the aircraft skin are controlled. However, a primary disadvantage of these types of designs is that they do not have a high degree of energy efficiency in reducing the density of the air in front of the aircraft where it is most needed because the emissions radiate outwardly in all directions. Moreover, the radioactive emissions can interfere with aircraft computer, radio and radar systems as well as being potentially dangerous to personnel within the aircraft or in the vicinity of the aircraft.

Still other prior art systems utilize laser beam radiation to heat the air passing through the beam and thereby rarefy the air through which the aircraft is moving. An example of such a system is disclosed in U.S. Pat. No. 5,263,661 to Riley. The Riley device uses a laser radiating a beam along the leading edge of an aircraft wing to the tip. The air passing through the beam as the aircraft flies through the atmosphere is heated and rarified thereby compressing more slowly as a result of the aircraft's motion than it normally would and creating a lower mass density thereof which is less favorable to development of a sonic boom. However, a primary disadvantage of such a system is that it has a high power requirement because laser radiation does not efficiently produce a high degree of heat energy in the air molecules. Moreover, as with the Schoppe system, this system also may produce excessive heating of the skin of the aircraft resulting in malfunction or failure of components of the aircraft.

Consequently, what is needed is a system for reducing the mass density of the fluid medium in the path of flight or movement of the aircraft or other type of vehicle as well as adjacent to the skin surfaces thereof in order to maximize reduction of the forces of friction and other drag forces acting on the aircraft during flight or on another type of vehicle during movement through another type of fluid medium. What is also needed is a system for reducing the mass density of the air proximal the aircraft (or of another type of fluid medium proximal another type of vehicle) which is able to provide such reduction of mass density very quickly and with a relatively high degree of energy efficiency. What is also needed is such a system which does not produce excessive heating of the vehicle.

SUMMARY OF THE INVENTION

It is a principal object of the present invention to provide a system for reducing the mass density of the fluid medium in front of a vehicle moving through the medium in order to reduce drag forces and sonic waves produced by the motion.

It is also an object of the present invention to provide a system for reducing the mass density of the fluid medium adjacent to and proximal to lateral and rearward portions of

a vehicle moving through a fluid medium in order to reduce drag forces and sonic waves produced by the motion.

It is also an object of the present invention to provide a system for reducing the mass density of the fluid medium through which a vehicle is moving which achieves the mass density reduction quickly and effectively.

It is also an object of the present invention to provide a system for reducing the mass density of the fluid medium through which a vehicle is moving which is relatively safe.

It is also an object of the present invention to provide a system for reducing the mass density of the fluid medium through which a vehicle is moving which is energy efficient.

It is also an object of the present invention to provide a system for reducing the mass density of the fluid medium through which a vehicle is moving which entails minimal interference with vehicle electronic components.

It is also another object of the present invention to provide a system for reducing the mass density of the fluid medium through which a vehicle is moving which is effective at both subsonic and supersonic speeds.

It is an object of the present invention to provide a system for reducing the mass density of the fluid medium through which a vehicle is moving which provides heat energy transfer with vehicle engine systems for enhanced energy and power efficiency.

It is an object of the present invention to provide a system for reducing the mass density of the fluid medium through which a vehicle is moving which provides a high degree of efficiency in producing a high degree of mass density reduction of the fluid medium.

It is an object of the present invention to provide a system for reducing the mass density of the fluid medium through which a vehicle is moving which does not produce excessive heating of the vehicle's outer surfaces.

Basically, the aerodynamic and hydrodynamic efficiency augmentation system of the present invention achieves its goal of reducing the mass density of the fluid medium through which a vehicle is moving by heating and ionizing the fluid medium proximal to the vehicle to a high temperature. The heating and ionizing is accomplished via radiation of tuned electromagnetic power outwardly from the vehicle into the fluid medium. The electromagnetic radiation is within the microwave range in order to maximize transfer of electromagnetic energy received by the fluid medium molecules into heat energy and to product the desired ion generation. In addition, the frequency of the electromagnetic radiation is at the harmonic resonance frequency of electromagnetic excitation of the particular type of molecules of which the medium is composed. Radiation at the harmonic resonance frequency maximizes the power transfer efficiency of the heating and ionizing of the fluid medium provided by the system of the invention.

The system of the present invention is particularly well suited for both subsonic and supersonic aircraft for which the effects of aerodynamic drag and sonic wave production are more pronounced. The system of the invention is also very suitable for Force Projection Vehicles type aircraft which utilize wing-in-ground effect airfoils generating almost double the normal lift capability because of a combination of ground effect and downwardly projecting airfoils (at the wing tips) that confine intruding air. Force Projection Vehicles normally cruise twenty feet above the sea over which they are most efficient but can also fly above land although at a higher altitude. Their low altitude capability renders them very advantageous in military operations

because they are relatively invisible to radar at such low altitude flight. However, Force Projection Vehicles, although also advantageous because effective and efficient in transport of large and heavy cargo, are currently limited to flight at relatively slow speeds. By substantially increasing maximum speed capability, the aerodynamic efficiency augmentation system can overcome this important shortcoming of Force Projection Vehicles. In addition, the system of the invention is also well suited for transatmospheric vehicles of many types. For these and similar types of applications in which the vehicle is moving through the atmosphere, the frequency of the electromagnetic radiation is preferably at the harmonic resonance frequency of electromagnetic excitation i.e., electromagnetic absorption peak, of oxygen. Oxygen (as well as water) has a substantial electric and magnetic dipole which can easily be excited by tuned microwave radiation. When ionized and heated, the oxygen molecules quickly transfer their heat energy to adjacent nitrogen and other component molecules of the medium resulting in quick and thorough heating and ionization of that portion of the atmosphere in the immediate path of the aircraft enabling the aircraft to fly in a thinner atmosphere resulting in reduced aerodynamic drag. Heating of the air decreases the pressure gradient at the front (and preferably also the rear) of the aircraft thereby destroying the coherency of the pressure fronts so that they do not add together coherently. This reduces the pressure gradients acting on the boundary layer between the ambient air and the aircraft because they are distributed over a larger region i.e., several meters rather than several centimeters. The system of the invention essentially produces a "hot air bubble" around the aircraft which reduces the expended power at true supersonic speeds because the coherent addition of pressure waves around the aircraft is degraded. This reduces or eliminates the energy transmitted to the shock cone i.e., the pressure field produced at supersonic speeds and located at the rear of the aircraft and extending therefrom in a widening cone, thereby preventing or reducing the build up of sonic waves and thus the reduction or elimination of a "sonic boom".

The system of the present invention can reduce the mass density of a fluid medium comprising either a liquid or gas and may even be utilized to reduce the mass density of a medium such as ice and thus increase the dynamic i.e., generally aerodynamic as well as hydrodynamic, efficiency of a vehicle moving through either air or water. Thus, the system may also be utilized for waterborne and underwater vehicles. For these types of vehicles the mass density of the water is reduced by irradiation at preferably the harmonic resonance frequency of electromagnetic excitation of water. As with aircraft, this enables the waterborne and underwater vehicles to move through the water with less inertial and/or viscous drag resisting their movement thereby allowing higher maximum speed and acceleration and reduced fuel consumption.

The torpedo seems to be the easiest application platform to which to apply this phenomena. The present invention could enable a torpedo to speed toward its target through an atmosphere of steam, stabilizing itself by a pair of fore and aft fins hydro-planing through the surrounding water. A submarine could enjoy the same advantage for a short period of time, unless some of the onrushing water were piped aboard for cooling purposes. Surface ships, of the sizeable displacement of current ocean going naval and commercial marine variety could ride a bubble of steam, effectively hydro-planing over the ocean's surface. The "steam bubble" would be the vehicle which would transmit the multi thou-

sand tons of weight to the ocean's surface, replacing the conventional displacement of water which provides the buoyant force for these vessels.

For transatmospheric (reentry) vehicle applications, the rarefaction of the atmosphere in the path of the vehicle also results in reduced frictional heating of the nose cone or other portions of the vehicle prone to overheating and provides increased protection to internal computer, electronic or other components sensitive to heat which may otherwise be damaged by or malfunction due to such heat generation.

For aircraft applications, the dynamic efficiency augmentation system incorporates microwave radiation generators mounted in the engines of the aircraft. The microwave generators exchange heat with the airflow entering and exiting the engine resulting in improved energy efficiency of both the engines and the generators. The induction airflow provides cooling for the generators while the exhaust airflow is provided with increased heating and thereby increased expansion of the engine exhaust gases resulting in improved thrust.

The output of the microwave generator is fed to an antenna which transmits the radiation through the interior of the aircraft and outwardly therefrom into the atmosphere in order to heat and thereby rarefy the air in the path of the aircraft as well as preferably rearwardly thereof. Thus, the microwave energy is radiated outwardly from preferably both the leading and trailing edges of the aircraft. In addition to transmission directly into the air, radiation transmission over portions of the skin of the aircraft produces heating and rarefaction of the air adjacent to lateral surfaces of the aircraft which tends to cling to the aircraft skin and produce viscous drag. The net effect is the production of a hot bubble of rarefied air surrounding the aircraft while it is moving through the atmosphere reducing aerodynamic drag on the aircraft and sonic wave generation (which also adds to aerodynamic drag). As a result, this reduces the fuel expenditure required for the aircraft to reach a desired speed and to maintain a cruise speed and its maximum attainable speed is also increased. In addition, it may attain supersonic speeds without generation of a sonic boom or with generation of a sonic boom of reduced intensity.

Molecules of the fluid medium which are substantially heated by the system of the present invention may come into contact with outer surfaces of the vehicle as a result of being in close proximity thereto or because they are located in the direct path of the vehicle. Due to the high temperature of these fluid medium molecules, substantial heat transfer to these vehicle outer surfaces may occur and result in the temperature of these and other components of the vehicle exceeding their maximal tolerable limits resulting in malfunction or failure thereof. For many applications, the fluid medium in the path of or proximal to the vehicle is preferably heated to a temperature which is in excess of the melting point of most metals. Consequently, a magnetic field subsystem is utilized to propel these heated molecules away from the vehicle and thereby prevent or minimize contact thereof with the vehicle's outer surface so as to minimize heat transfer to the vehicle's outer surface. By propelling these molecules away from the vehicle, the magnetic field subsystem also produces further rarefaction of the fluid medium through which the vehicle is moving thereby enhancing the benefits afforded by such heating of the fluid medium.

Heating the fluid medium to very high temperatures results in ionization of at least some of the molecules of the fluid medium. Where the fluid medium is air, this ionization

results especially when the radiation first enters the air where oxygen molecules are present. Although the resulting rarefaction process propels the air molecules away from each other in many directions, the velocity of the vehicle results in a direction of relative motion between the ions and the vehicle's outer surfaces which is approximately parallel to generally the lateral and horizontal portions of the vehicle's outer surfaces (which in the case of aircraft are the upper and lower surfaces of the wings, sides of the tail and sides of the fuselage). The magnetic field generated by the system of the invention is oriented so that its lines of force are perpendicular to both the direction of ion flow across the vehicle's outer surfaces as well as the vehicle outer surfaces. Interaction of these charged molecules or particles results in a force which propels the molecules or particles in a direction perpendicular to the direction of motion of the vehicle. Depending on whether the molecules or particles have a positive or negative charge and on the direction of the magnetic lines of force, the molecules or particles are propelled either toward or away from the vehicle's outer surfaces. Thus, in aircraft applications, the positively charged air molecules are forced away from the aircraft's wing and fuselage surfaces while the negatively charged electron particles (stripped from the ionized air molecules) are forced onto or toward the aircraft's wing and fuselage surfaces. The electrons collecting on the metallic outer surfaces of the aircraft will be conducted all over the exposed surfaces of the aircraft and attach themselves to air molecules adhering to these surfaces. These air molecules are the sources of viscous drag and, as such, retard the velocity of the aircraft in direct proportion to its velocity. By providing a negative charge to these adhering air molecules, they will be attracted to the positively charged ions generated by the RF radiation and located away from the aircraft's outer surfaces. Thus, these ions will attract and move toward each other with the result that the adhering air molecules which are combined with the electrons will be drawn off and away from the aircraft's wings and fuselage thereby reducing viscous drag on the aircraft's surface. These ions subsequently re-combine at locations distal from the aircraft's metallic components.

The calculations that follow provide a determination of the power needed as well as other parameters of the system components required to provide that power needed to heat the onrushing air from approximately zero degrees to 1800 degrees Centigrade for a typical fighter aircraft in flight where the wings of the aircraft are D meters wide and the aircraft velocity is $v=1000$ mph. In the calculations it is assumed that the column of onrushing air is $\pm y$ meters on either side of the wings. The mass of the air encountered by the wings (whose cold air density is 1.29 kgrams/meter³) which must be heated every second is:

$$[2y \times D \times v \times 1.29] \times [273 \text{ degrees Kelvin} / 2073 \text{ degrees Kelvin}]$$

Note that the factor $[273 \text{ degrees Kelvin} / 2073 \text{ degrees Kelvin}]$ is due to the expansion of a small amount of air whose volume will increase by this factor once it is heated to 1800 degrees Centigrade. This factor determines the ratio of the divergence of the radiated beam to the angle subtended by the column of heated air.

For a fighter aircraft flying at 1000 mph (or 514 meters/second) with wings 12 meters wide, the power needed to heat the air \pm one meter above and below the wing's edge is:

$$2 \times 1 \times 12 \times 514 \times 1.29 \times 0.1317 = 2096 \text{ kgram/seconds}$$

The change in the specific heat of the air when its temperature is increased from 100 degrees Centigrade

(0.2404 cal/gram) to 1800 degrees Centigrade (0.2850 cal/gram) is 0.0446 cal/gram, and this leads to the following:

$$4.18 \text{ joules/cal} \times 0.0446 \text{ cal/gram} = 0.1864 \text{ joules/gram} = 0.1864 \text{ kjoules/kgram}$$

Thus, the power which must be transmitted into the air in front of the wings is:

$$0.1864 \text{ kjoules/kgram} \times 2096 \text{ kgram/sec} = 391 \text{ kjoules/sec} = 0.4 \text{ megawatt}$$

To heat a column of air R meters in radius i.e., a size sufficient to permit the aircraft's fuselage and engine nacelles to pass therethrough, requires:

$$\pi \times R^2 \times v \times 1.29 \text{ (density of cold air)} \times 273 \text{ degrees Kelvin} / 2073 \text{ degrees Kelvin}$$

For an aircraft fuselage (and nacelles) 2 meters in radius requires:

$$\pi \times 4 \times 514 \times 1.29 \times 0.1317 = 1098 \text{ kgram/sec}$$

Thus, the power which must be transmitted into the air is:

$$0.1864 \text{ kjoules/kgram} \times 1098 \text{ kgram/sec} = 205 \text{ kjoules/sec} = 0.2 \text{ megawatt}$$

The total power required = 0.4 megawatt + 0.2 megawatt = 0.6 megawatt.

Assuming that the air is heated by first ionizing the oxygen molecules to their first ionization state, then this energy is shared by mutual excitation (rotation) of the nitrogen molecules so that the nearby air molecules eventually rise to as high as a temperature of about 1800 degrees Centigrade. A triangular (in cross-section) beam $\pm A^\circ$ wide at the front edge or tip portion of the aircraft fuselage (and engine nacelle) and extending b meters from it must be formed to heat this column of air. It will be assumed that all the oxygen molecules in this region will be ionized every time the 60 GHz beam produced by the microwave generator fires, and the duty cycle of this transmission is 0.0012. The first ionization potential, I_p is 4.8844×10^4 kjoule/kgram. It is believed that air exists in an ionized state out to at least b (6 meters). The instantaneous mass of oxygen excited by the 60 GHz radio frequency beam = I and is provided by:

$$I = \pi \times D \times \frac{1}{2} \times b \times (2 \times b \tan A) \times 0.2 \text{ (air: 20% oxygen)} \times 1.29 \text{ kgram/m}^3 \text{ (cold air density)}$$

$$I = 3.1416 \times 30 \times 6 \text{ m (assumed extent of ionization)} \times 6 \times \tan 1.24^\circ \times 0.2 \times 1.29$$

$$I = 18.9519 \text{ kgram}$$

The average ionization power expended P_i is:

$$P_i = I_p \times I \times \text{transmission duty cycle} = 4.8844 \times 10^4 \text{ kjoule/kgram} \times 18.95 \text{ kgram} \times 0.0012$$

Thus, the ionization power expended is:

$$P_i = 1.1 \text{ megajoules per second} = \text{approximately } 1 \text{ megawatt}$$

The half beam-width required to ionize a column of air r meters (1 meter) in radius a distance b meters (6 meters) in front of the aircraft's fuselage is given by:

$$A^\circ = \tan^{-1}(r/b) = \tan^{-1}(1/6) \approx 9.5^\circ$$

The microwave beam is preferably radiated outwardly from the aircraft into the column of air by means of a

forward refocusing cassagrain antenna. The size z of the aperture which is the focus of the secondary antenna of the forward refocusing cassagrain antenna (assuming 60 GHz power) to generate a beam $2 \times A^\circ$ wide is:

$$z = 65^\circ \times 0.5 \text{ cm. (wavelength for 60 GHz RF)} / (2 \times A^\circ) = 65^\circ \times 0.5 \text{ cm} / (19^\circ)$$

$$z = 1.7 \text{ cm.}$$

The size d of the cassagrain primary needed to form a beam 2.5° wide is:

$$d = 65^\circ \times 0.5 \text{ cm.} / (A^\circ) = 65^\circ \times 0.5 \text{ cm.} / (2.5^\circ) = 13 \text{ cm.}$$

The magnetic field propelling the ions away from the outer surfaces of the vehicle is provided by a set of electric coils or looped wires in one embodiment and by a set of magnetic slabs in another embodiment. For the electric coil embodiment providing an electromagnet, the magnetic flux density in the vicinity of an aircraft's fuselage or wing outer surfaces required to propel the ionized molecules a desired distance therefrom may be determined from the following equations in which the electric loops are configured so that they are in the shape of a sphere. Utilizing a cylindrical coordinate system, the magnetic field H in the region outside the sphere is given by:

$$H = (m/4 \pi r^3) \times (i_z \cos \theta + i_\theta \sin \theta)$$

$$H = m/2 \pi R^3 i_z$$

$$m = 4 \pi R^3 K_o / 3$$

where the cylindrical coordinates are the standard r , θ and z ; R =radius of the sphere; $r > R$; m =magnetic moment; K_o =current density.

The magnetic flux density B is given by:

$$B = \mu_o H = (1/4 \pi r^3) \times (4 \pi R^3 K_o / 3) \times \sin \theta$$

Assuming ions approximately 15 centimeters from the aircraft's outer surfaces must be effected by the magnetic field and $\theta = 45^\circ$, the resulting value for B is given by:

$$B = 3.04 \times 10^{-7} \times K_o$$

Assuming the wire needed for the coils is approximately $1/8$ inch in thickness, a single layer of 312 wires per meter is sufficient. The Gyrotron utilized in the aircraft requires approximately 3×10^5 watts to drive it. Assuming a generator providing 400 volts is powering it, then the electric coils must be supplied with at least 750 amperes (and possibly twice this value) per Gyrotron. The value of the current density of the coils is

$$K_o = 750 \times 312 = \text{approximately } 2.25 \times 10^5 \text{ amperes per meter}$$

The numerical value for B becomes:

$$B = 3.04 \times 10^{-7} \times K_o = 7 \times 10^{-2} \text{ webers per meter}$$

The force on an ion is:

$$F = q v_o B = 1.6 \times 10^{-19} \times 500 \text{ meters per second} \times 7 \text{ webers per square meter}$$

$$F = 5.7 \times 10^{-18} \text{ newtons}$$

But, since $F = M \Delta v / \Delta t$ and assuming that the force is applied over approximately one-half of a meter of the wing surface (as the aircraft moves forward), then $\Delta t = 10^{-4}$ seconds.

Since $F = M \Delta v / \Delta t$, then $\Delta v = F \times \Delta t / M$

where $M = 32 \text{ grams} / \text{Avogadro's number} = 32 / 6.03 \times 10^{-26} \text{ kilograms}$

The acceleration imparted to the ion is given by:

$$\Delta v = F \times \Delta t / M = (5.7 \times 10^{-18} \text{ newtons} / 5.3 \times 10^{-26} \text{ kilograms}) \times 10^{-4} \text{ seconds}$$

$\Delta v = 10^5$ meters per second.

Since this velocity Δv is perpendicular to the aircraft's outer surfaces and is applied for 10^{-4} seconds, the positively charged ions are propelled away from the aircraft's outer surface a distance of approximately one meter by this magnetic field.

BRIEF DESCRIPTION OF THE DRAWINGS

FIG. 1 is a graphical representation showing the atmospheric attenuation of microwave radiation by oxygen and water molecules thereof and illustrating their absorption peaks.

FIG. 2 is a side cross-sectional view of an aircraft wing depicting the ion flow across the upper and lower surfaces thereof and also the lines of force of the magnetic field produced by the magnetic field subsystem of the invention and showing the direction of the forces acting on the ions.

FIG. 3 is a sectional view of a representative magnet utilized in the magnetic field subsystem of the invention and illustrating the shape of the magnetic field lines which are ultimately formed by the magnetic field subsystem which is shaped to provide the laterally elongated lines of force configuration shown.

FIG. 4 is a plan view of a typical turbofan jet engine suitable for use with the aerodynamic efficiency augmentation system of the present invention.

FIG. 5 is a plan view of a continuous wave gyrotron type of microwave radiation generator component of the aerodynamic efficiency system of the invention.

FIG. 6 is a plan view of the gyrotron mounted in an aircraft jet engine and positioned for heat exchange therebetween and also showing the antenna therefor.

FIG. 7A is a top plan view of the aerodynamic efficiency augmentation system of the invention mounted in an aircraft and showing the microwave beams radiated into the atmosphere in front of the aircraft.

FIG. 7B is a side plan view of the aerodynamic efficiency augmentation system of the invention mounted in an aircraft and showing the microwave beams radiated into the atmosphere in front of the aircraft.

FIG. 8 is a diagram of components of a first embodiment of the invention showing microwave beams radiated through a wing and fuselage portion of an aircraft and radiated into the atmosphere in front of the leading edge of the wing and in the rear of the trailing edge of the wing.

FIG. 9 is a diagram of components of the first embodiment of the invention shown in FIG. 8 for the radiation beams directed into the atmosphere in front of the leading edge of the wing and illustrating the beam, the mirrors and antenna and the orientation and placement thereof.

FIG. 10 is a diagram of components of the first embodiment of the invention shown in FIG. 8 for the radiation beams directed into the atmosphere rearward of the trailing edge of the wing and illustrating the beam, the mirrors and antenna and the orientation and placement thereof.

FIG. 11 is a diagram of components of the first embodiment of the invention shown in FIGS. 8, 9 and 10 and

additionally showing components utilized to radiate the microwave beam from the fuselage of the aircraft outwardly into the atmosphere both in front of the fuselage and along the leading edge of the wing.

FIG. 12 is a top plan view of components of the magnetic field subsystem of the first embodiment showing the electromagnet producing coiled wires thereof mounted in the wings of the aircraft.

FIG. 13 is a side cross-sectional view of a representative one of the wings of the aircraft showing the coiled wire components of the magnetic field subsystem in addition to components of the electric power recovery subsystem utilized to obtain electrical power from the ion flow in the aircraft wing.

FIG. 14 is a diagram of components of a second embodiment of the invention showing microwave beams radiated through a wing portion of the aircraft and radiated outwardly into the atmosphere in front of the leading edge of the wing and in the rear of the trailing edge of the wing.

FIG. 15 is a diagram of the components of the second embodiment of the invention shown in FIG. 14 and specifically showing in more detail components utilized to radiate the microwave beam through the wing portion of the aircraft and radiated into the atmosphere in front of the leading edge of the wing.

FIG. 16 is a diagram of the components of the second embodiment of the invention shown in FIG. 14 and specifically showing in more detail components utilized to radiate the microwave beam through a wing portion of the aircraft and radiated into the atmosphere rearward of the trailing edge of the wing.

FIG. 17 is a diagram of the components of the second embodiment of the invention shown in FIGS. 14, 15 and 16 and specifically showing in more detail components utilized to radiate the microwave beam from the fuselage of the aircraft outwardly into the atmosphere both in front of the fuselage and along the leading edge of the wing.

FIG. 18 is a top plan view of components of the magnetic field subsystem of the second embodiment showing the electromagnet producing coiled wires and the magnetic slabs thereof mounted in the wings of the aircraft.

FIG. 19A is a side cross-sectional view of a representative one of the wings of the aircraft showing the coiled wire components of the magnetic field subsystem in addition to components of the electric power recovery subsystem utilized to obtain electrical power from the ion flow in the aircraft wing.

FIG. 19B is a side cross-sectional view of a representative one of the wings of the aircraft showing the magnetic slab components of the magnetic field subsystem in addition to components of the electric power recovery subsystem utilized to obtain electrical power from the ion flow in the aircraft wing.

DETAILED DESCRIPTION OF THE PREFERRED EMBODIMENT

Basically, the aerodynamic efficiency system of the invention utilizes the microwave frequency selective absorption peaks of oxygen to provide effective and efficient heating of portions of the atmosphere in the path of a vehicle moving therethrough. Water and oxygen have electric and magnetic dipoles which enable them to more readily vibrate in response to microwave radiation. The microwave absorption peaks shown in FIG. 1 are the microwave frequencies at which harmonic resonance excitation of these types of

molecules occur which maximizes heat produced in response thereto. As shown in FIG. 1, maximum attenuation of radiation occurs at the first oxygen peak of approximately sixty GHz and this is therefore the frequency deemed optimum for energy efficient heating of the atmosphere. However, nitrogen molecules do not have significant dipole properties and therefore cannot efficiently be heated by microwave radiation. Consequently, the nitrogen molecules in the atmosphere (as well as other types of molecules therein) are instead indirectly heated by direct physical transfer of the thermal motion from oxygen molecules which are proximal thereto thereby producing rapid heating of an entire desired portion of the atmosphere. As is also evident from FIG. 1, microwave radiation can also be used to heat a medium composed partly or entirely of water thereby allowing a vehicle to move with less friction through a "tunnel" or "channel" of rarefied steam (e.g., steam) in the path of the vehicle.

Two preferred means of applying the concept of the present invention to a jet aircraft are described in a first embodiment and a second embodiment generally designated by the numerals 10 and 110, respectively. The first and second embodiments differ only in how the RF energy used to heat the air is fed in front of the wing assembly. The first embodiment 10 radiates a beam along the front edge of the wing. Part of the beam is initially contained within the wing assembly and diverges from this containment as it radiates along the front edge of the wing. A component structure of the first embodiment 10 permits passage of this beam both within and without the wing's forward edge surface. Some attenuation of the beam by the component structure can be expected, but it is not immediately quantifiable. For the second embodiment 110, the entire beam is initially contained within the wing assemblies as it radiates from its source. However, component structures of the second embodiment 110 intercept parts of this beam and radiate it outward through the forward edge of the wing.

FIGS. 4, 5 and 6 depict components of the invention common to both embodiments and used in essentially the same way. FIG. 4 shows a typical jet engine 12 (112) between the low pressure fan 28 (128) and the compressor turbine fans 21 (121) thereof which is suitable for use with the concept of the present invention, and FIG. 5 depicts a microwave electromagnetic radiation generator 14 (114) and FIG. 6 shows the generator 14 (114) positioned in such an engine 12 (112) for heat transfer between the induction and exhaust airflows 16 (116), 18 (118) and the generator 14 (114). The microwave generator 14 (114) is preferably a gyrotron tube 14 (114) although other suitable types of microwave generators may also be utilized. The gyrotron tube 14 (114) is thus attached to the engine 12 (112) before the compressor 25 (125) and the compressor turbine fan 21 (121) and arranged so that it is in the path of the dense flow of air after the bypass fan 28 (128) of a low or high bypass jet engine 12 (112) but before the compressor of the engine 12 (112), as shown in FIG. 4 and with reference to FIG. 2. The gyrotron tube 14 (114) is also preferably oriented so that it is approximately transverse to the axis of the jet engine 12 (112), as shown in FIGS. 4, 6, 7, 10 and 11. The gyrotron tube 14 (114) has an electron collector 22 (122) which is the major source of heat due to the relative high density and high velocity of the electron beam and super conducting magnets 23 (123) which must be kept cool to provide maximum power efficiency in maintaining magnetic field strength. The electron collector 22 (122) is conventional in structure and function and is preferably cooled with water (although liquid sodium may also be suitable) as with conventional gyrotron

designs preferably via a conventional radiator subsystem suitably positioned in the path of the airflow 16 (116), while the super-conducting magnets are located at outermost portions of the engine 12 (112) and wings 24 (124) of the aircraft 20 (120) thereby obtaining the required cooling directly from the atmosphere. The electron gun of the gyrotron 14 (114) forms an electron beam which is accelerated through the focusing field of the magnets 23 (123) to the electron collector 22 (122). The electrons of the beam interact with radio-frequency electric fields perpendicular to the magnetic focusing field. The rotation of the electrons in the field and the alternation of the fields in synchronism therewith produce a cumulative interaction resulting in an oscillation. The interaction between the electrons and the fields causes the electrons to bunch in an elongate configuration parallel to the axis of the electron trajectories enabling extraction of energy from the electrons and by utilizing the resonance nature of the interaction producing the desired high frequency output. As shown in FIG. 6, the coolant vanes 26 (126) of the gyrotron tube 14 (114) are preferably mounted inside the engine 12 (112) for heat exchange with the induction airflow passing through the engine 12 (112). The vanes 26 (126) are preferably curved to conform with the laminar flow of the air generated by the bypass fans 28 (128) of the engine 12 (112), but they are depicted as straight for simplicity of illustration. The heat from the electron collector 22 (122) is transferred to the airflow 16 (116) passing into the low pressure fan 28 (128) used to generate compressed cold air which is mixed with the engine's gas turbine hot exhaust 18 (118). The temperature of the exhaust airflow 18 (118) is thereby increased providing increased engine thrust while the electron collector 22 (122) is cooled without necessitating the energy burden of a cooling subsystem specifically for cooling the collector. Thus, the efficiency of both the generator 14 (114) and the engine 12 (112) are improved. This heat exchange could be used in a high bypass jet engine as well as a low bypass turbofan jet engine the latter of which would be more effective because a two or three stage low pressure fan is used to generate compressed cold air (a high pressure compressor feeds the jet engine's fuel/air mixture).

The first embodiment 10 of the invention is shown generally in FIGS. 7A and 7B and more specifically in FIGS. 8, 9, 10, 11, 12 and 13. The first embodiment includes the generators 14 and the components thereof which are mounted in the engines 12 of the aircraft 20, as described generally above. The generators 14 preferably include a pair of continuous wave gyrotrons 15 and 17 and a pulse gyrotron 19 mounted in each of the engines 12. The pulse gyrotron 19 provides pulsed radiation which is emitted from preferably the front portion of the fuselage 30 of the aircraft 20 in order to allow radar and continuous wave (cw) communication subsystems to be used in the aircraft. High speed interruption of the low frequency audio rates employed on a single channel VHF or UHF (cw) radio transmitter is tolerable for such transmissions where the gyrotron 19 operates with a pulse repetition interval of four-hundred microseconds (2500 pulses per second) and would also permit a thirty mile weather or engagement radar subsystem to operate effectively. The gyrotron 19 preferably operates with a fifty percent duty factor, on for four-hundred microseconds and off for four-hundred microseconds. It is believed that pulsed gyrotrons produce greater ionization of the medium into which they emit their radiation.

All of the gyrotrons 15, 17 and 19 utilize antennas to radiate the microwave energy both directly outwardly of the aircraft 20 into the atmosphere and into and through inner

structures of the aircraft 20 to locations where the energy may be radiated directly into the atmosphere. Sets of preferably cassagrain types of output antennas 32, 76 and 78 are mounted at the output of each of the gyrotrons 15, 17 and 19 to emit the radiation into and through conduits which are preferably nitrogen filled waveguides 34 (or simply nitrogen filled passageways) located within the wing 24 of the aircraft 20, as shown in FIG. 11. However, other types of microwave radiation waveguides or conductors may also be utilized if desired and as appropriate for the particular application. Preferably an inverse cassagrain type of antenna 36 is mounted at appropriate fuselage portions of the aircraft 20 for receiving the transmitted through the waveguides 34 and emission of the radiation directly into the atmosphere. The waveguides 34 preferably include a first set of waveguides 38, a second set of waveguides 40 and a third set of waveguides 42. The first set of waveguides 36 are preferably mounted within the wing 24 and positioned at the output of the gyrotrons 15 (and antennas 32) in order to receive the radiation output therefrom and transmit and direct it to a first set of (preferably contoured) radomes 44 at leading edges 46 of the wing 24. The second set of waveguides 40 are preferably also mounted within the wing 24 and positioned at the output of the gyrotrons 17 (and antennas 76) in order to receive the radiation output therefrom and transmit and direct it to a second set of radomes 48 at trailing edges 50 of the wing 24. The third set of waveguides 42 are preferably mounted within the wing 24 and the fuselage 52 and positioned at the output of the gyrotrons 19 (and antennas 78) in order to receive the radiation output therefrom and transmit and direct it to a third set of radomes 54 at the front portion (or tip) 30 of the fuselage 58. The sets of radomes 44, 48 and 54 are preferably composed of sintered aluminum oxide to provide heat and oxidation resistance while also allowing the microwave radiation to pass therethrough into the atmosphere. The sets of radomes 44, 48 and 54 are also positioned at surface portions of the aircraft 20 in the path of the microwave radiation beams exiting the aircraft 20 and emitted into the atmosphere.

A first set of mirrors 56 are also included and positioned at preferably the distal end of the first set of waveguides 38 for receiving the radiation beam transmitted through the set of waveguides 38 and reflecting the beam generally backward into and through the first set of radomes 44 and outward into the atmosphere in front of the wing's 24 leading edge 46. The reflected beam is preferably angled relative to the leading edge 46 so that it is nearly parallel thereto and more preferably at an angle of approximately fifteen degrees relative thereto, as shown in FIGS. 8 and 9. Thus, the beam is oriented such that although it is projected so that it is directly in front of the entire length of leading edge 46 it is not positioned at an excessive distance from any portion of the leading edge 46 and therefore does not heat a portion of the atmosphere an excessive distance from the leading edge 46.

The output of the continuous wave gyrotron 15 is fed into the first set of cassagrain output antennas 32 which are oriented so that they emit the radiation directly into the first set of waveguides 38 as well as into and through the first set of radomes 44, as shown in FIG. 9. Thus, a portion of the beam emitted from the output antenna 32 is transmitted into the first set of waveguides 38 while another portion of the beam emitted therefrom is transmitted into the first set of radomes. The portion of the radiation beam transmitted through the first set of radomes 44 directly from the output antenna 32 is emitted into the atmosphere directly in front of the leading edge 46 and approximately parallel thereto. The

beams reflected into the atmosphere in front of the leading edge 46 from the mirrors 56 and directly from the output antenna 32 are directed generally towards each other.

The output of the continuous wave gyrotron 17 is fed into another set of cassagrain output antennas 76 which radiate the microwave beam into and through the second set of waveguides 40. A second set of mirrors 58 positioned in the second set of waveguides 40 reflects and directs the beam into and through the second set of radomes 48 into the atmosphere directly rearward of the trailing edges 50. More specifically, the radiation beam is radiated through the second set of waveguides 40 onto a second set of mirrors 58, located at approximately midwing, which direct the beam rearwardly. The second set of radomes 48 at the trailing edges are wider than the first set of radomes 44 at the leading edge and consequently a larger region of aft wing heats the air leaving the wing's surface.

A portion of the microwave beam transmitted through the second set of waveguides 40 is directed onto a third set of mirrors 60 located in the fuselage 52 which reflect the beam toward a fourth set of radomes 62 located at the vertical leading edge 64 of the tail stabilizer 66. More specifically, a third set of mirrors 60 located at a bend in the waveguide (preferably in the fuselage 52) reflects the beam rearwardly through the waveguide 40 and the fuselage 52 to another of the third set of mirrors 60 located proximal the tail stabilizer 66 which reflects the beam into and through the fourth set of radomes 62 and outwardly into the atmosphere directly in front of the tail stabilizer 66 leading edge 64. The beam emitted into the atmosphere from the fourth set of radomes 62 is oriented so that it is generally parallel to the tail stabilizer's 66 leading edge 64, as is the beam emitted from the antenna 32 directly into the atmosphere in front of the leading edge 46 of the wing 24, as described above.

The output of the pulsed gyrotron 19 is fed to the third set of the cassagrain antennas 78 which radiate it into and through the third set of waveguides 42 and through the third set of radomes 54 into the atmosphere directly in front of the front portion 30 of the fuselage 52. As shown in FIGS. 8 and 11, a fourth set of mirrors 68 located in the fuselage and at a bend in the third set of waveguides 42 reflects the beam forwardly through the fuselage 52 into one of the inverse cassagrain antennas 36 which emits the radiation beam into and through the third set of radomes 54. As with the other of the inverse cassagrain antennas 36, this inverse cassagrain antenna 36 emits a broadened beam of radiation into the atmosphere directly in front of the front portion 30 of the fuselage 52. In addition, there is also a seventh mirror or set of mirrors 70 mounted in the fuselage 52 which receives, reflects and directs a portion of the pulsed radiation beam transmitted through the fuselage 52 into and through the first set of radomes 44 and outwardly into the atmosphere directly in front of the leading edge 46. As described above, the radiation emitted from the fuselage 52 is pulsed in order to allow both radar and continuous wave communications signals to be transmitted and received while the aerodynamic efficiency augmentation system of the present invention is in operation.

Since the heat energy of the air molecules proximal to the aircraft 20 may be readily transferred to the outer surfaces of the aircraft 20 due to proximity or due to direct contact therewith resulting from motion of the aircraft 20 through the rarefied atmosphere, it is necessary that these hot air molecules be prevented from getting too close to the outer surfaces of the aircraft 20. Consequently, a magnetic field subsystem 80 is provided to direct and propel the air molecules away from the aircraft 20 when the molecules get

within the effective range of the magnetic field produced by the subsystem 80.

FIG. 2 shows the orientation of the magnetic field produced by the subsystem 80. Since the ionized air molecules 82 and electrons 84 flow over the aircraft's outer surfaces or skin 74 (which are also specifically depicted as the upper and lower surfaces 86 and 88 of the wing 24 shown in FIG. 2) in a direction of flow 92 which is generally parallel to these surfaces 74, the lines of force 94 are oriented so that they are generally perpendicular to this direction of flow 92. The magnetic field and lines of force 94 thereof are also oriented so that the interaction of the lines of force 94 with the charged molecules or particles 82 and 84 produces a force acting thereon which propels them in a direction perpendicular to the outer surfaces 74 and perpendicular to the lines of force 94. The ions 82 and 84 flowing over the upper surfaces 86 interact with the lines of force 94 which are directed out of the illustration of FIG. 2 so that the positive ions 82 are propelled vertically away from the upper surfaces 86 by the force 87 acting thereon while the negative ions 84 are propelled vertically toward the upper surfaces 86 by the force 89 acting thereon. The positively charged air molecules 82 which contribute mass densities greater than the negatively charged ions i.e., the electrons, 84 thus contribute higher quantities of heat energy. Thus, propelling these positively charged ions 82 away from the aircraft 20 producing less likelihood of contact therewith and heat transfer thereto minimizes the likelihood that the system's radiation heating of the atmosphere will result in excessive heating of the aircraft 20. This reduces the need to utilize heat shields, exotic metals or interior insulation to protect the aircraft components, instruments, etc. This also further rarefies the atmosphere proximal to the aircraft 20 thereby enhancing the increased dynamic efficiency afforded by the system 10.

The magnetic field subsystem 80 preferably utilizes a set of coiled wires 96 preferably mounted in the wings 24 preferably at the upper and lower portions thereof, as shown in FIGS. 12 and 13. The sets of coiled wires 96 are fed electrical current via current distributors 95. The set of coiled wires 96 are preferably wound horizontally around the core or center of each wing 24 so that the coils of each set 96 lie in the same plane and have the same approximate center and are proximal the periphery of the wing. Each set of coiled wires thus produces an electromagnet which is vertically oriented so that its poles are in vertical alignment. The set of coiled wires 96 thus produce a magnetic field whose lines of force 94 extend laterally over the upper and lower surfaces 86 and 88 of the wings 24, as illustrated in FIG. 2. The set of coiled wires 96 thus also produce a magnetic field whose magnetic flux density vectors 97 point toward the fuselage 52 on one side thereof and point away from the fuselage 52 on the other side thereof. The lines of force 94 are thus oriented generally horizontally and generally perpendicular to the direction of ion flow across the outer surfaces 74 providing the desired deflection of the ions in a direction perpendicular to the upper and lower surfaces 86 and 88 (and perpendicular to the direction of motion of the aircraft 20). However, other lines of force 94 provided by the set of coiled wires 96 will not have this particular desired orientation. Other lines of force located at the center line of the aircraft 20 are generally parallel to the direction of flow 92 of the ions and would thus not affect the direction of motion of the ions. Still other lines of force may have different orientations which may instead propel the ions in other directions. Nevertheless, since the lines of force 94 with the described desired orientation are located immedi-

ately rearward of the radomes 44 at the leading edges 46 of the wings 90, they will produce the desired deflection of the ions as soon as the ions enter the space directly above or below the wings 24, whereas the lines of force which have a more vertical orientation are located more rearward of the leading edges of the wings 24 at which location there are relatively few ions close enough to the outer surfaces 74 to result in the undesired heat transfer thereto. Consequently, at least most of the ions that can result in the undesired heat transfer are removed from proximity to the outer surfaces 74 of the aircraft 20 by the subsystem 80.

The negatively charged ions 84 are directed toward and onto the outer surfaces 74 of the wing 24 (as well as the fuselage, tail, etc.). The electrons 84 collecting on these outer surfaces 74 will be conducted all over the exposed surface of the aircraft and attach themselves to air molecules adhering to these surfaces thereby transferring a negative charge to these air molecules. These air molecules are the sources of viscous drag and, as such, retard the velocity of the aircraft in direct proportion to its velocity. But, once these air molecules acquire the negative charge, they are attracted to the positively charged air molecules 82 more distal of these outer surfaces 74. These positively charged air molecules 82 are produced by the radiation generated by the system 10. The mutual attraction between these ions draws these molecules adhering to the outer surfaces 74 off and away from the surfaces 74 thereby reducing viscous drag acting on these outer surfaces 74.

Additionally, air molecules adhering to the outer surfaces 74 may be drawn from other portions thereof at which the magnetic subsystem 80 is not adequately effective in removing the adhering air molecules by heating these portions of the outer surfaces 74. In order to provide this heating of the outer surfaces 74, some of the remaining microwave radiation is fed directly from the output antenna 32 to the electromagnetically conducting skin 74 (preferably portions thereof from which the magnetic subsystem 80 is not adequately effective in removing adhering air molecules) of the wing 24 by means of an electric conductor (or waveguide) 72, as shown in FIG. 9. The microwave radiation is thus allowed to be transmitted directly through the outer surface 74 of the wing 24 (and other parts of the aircraft 20 such as the fuselage 52, if desired). This radiation being conducted through the outer surfaces 74 heats the air adjacent thereto resulting in reduced viscous drag for these portions of the aircraft 20.

The presence of the negatively charged ions 84 produced by the radiation heating of the atmosphere proximal to the aircraft 20 and the propelling of the negatively charged ions 84 toward and onto the aircraft 20 result in a high relative concentration of negatively charged ions 84 at the outer surfaces 74. The presence of these ions 84 in combination with the forward motion of the aircraft through this ionized air plasma results in backward flow of negatively charged ions over the aircraft 20. The backward flow of negatively charged ions (electrons) 84 over the outer surfaces 74 induces an electrical current in the outer surfaces 74 which also flows backward. In order to extract this current flow and allow it to be utilized to power electrical units of the aircraft 20, the panels 98 (shown in FIG. 13) of the upper outer surfaces 86 have to be electrically isolated from the lower outer surfaces 88 in order to prevent merging and neutralization of these currents at the trailing edges 50 of the wing 24 via insulator panels 90. Ion collector plates 99 are also provided and positioned directly underneath the panels 98 of the upper surfaces 86 and directly above the panels 98 of the lower surfaces 88 in order to collect the electrical current

flowing through surfaces 86 and 88. A set of electrical wires 91 connected to the ion collector plates 99 receive the electrical current therefrom and allow it to be used to provide electrical power to other subsystems and electrical units of the aircraft 20.

FIGS. 14, 15, 16, 17, 18, 19A and 19B show the second embodiment of the invention 110 which is essentially identical to the first embodiment 10 except that the microwave beams are radiated outwardly in front of the leading edges 146 in a direction generally parallel to the direction of motion of the aircraft 120 rather than at a small angle (or nearly parallel) to the leading edge 46 i.e., approximately perpendicular to the direction of motion, as in the design of embodiment 10 and that the magnetic field subsystem 180 additionally includes permanently magnetized slabs 181. The rays of the radiation beam emitted from the leading edges 146 are also divergent from each other, as shown in FIG. 14. In the embodiment 110, a fifth set of mirrors 155 is provided which receive the radiation beam emitted from the first set of cassagrain output antennas 132. The fifth set of mirrors 155 are located in the first set of waveguides 138 at locations along the length thereof behind the leading edges 146 of the wings 124, as shown in FIG. 14. The fifth set of mirrors 155 are oriented so that they reflect and direct the radiation beam into and through a first set of radomes 144 mounted at the surface portions of the leading edges 146 and into the atmosphere directly in front of the leading edges 146. The remainder of the radiation beam transmitted through the first set of waveguides 138 which is not emitted through the first set of radomes 144 via reflection from the fifth set of mirrors 155 is reflected off a first and sixth set of mirrors 156 and 157 located at the inner end portion of the first set of waveguides 138 at or proximal to the fuselage 152 and directed to the first set of radomes 144 at the leading edge 146 of the wing for emission into the atmosphere in front of the leading edge 146. The radiation beam emitted from the first set of mirrors 156 through the first set of radomes 144 is oriented such that it is preferably angled relative to the leading edge 146 so that it is nearly parallel thereto and more preferably at an angle of approximately fifteen degrees relative thereto, as shown in FIG. 14 and similar to the angle produced by the first set of mirrors 56 of embodiment 10. The sixth set of mirrors 157 is oriented so that it is more nearly perpendicular to the direction of transmission of the radiation beam through the first set of waveguides 138 and thus reflects and directs the radiation beam through the first set of radomes 144 in a direction laterally outward from the aircraft 120 and in front of the leading edge 146. The sixth set of mirrors 157 is oriented so that the angle of the radiation beam reflected therefrom is more obtuse than that of the beam reflected from the first set of mirrors 156 and this angle is preferably approximately 30 degrees. Thus, each of the beams is oriented such that although it is projected so that it is directly in front of the entire length of leading edge 146 it is not positioned at an excessive distance from any portion of the leading edge 146 and therefore does not heat a portion of the atmosphere an excessive distance from the leading edge 146.

As shown in detail in FIG. 16, the output of the continuous wave gyrotron 117 is fed into a second set of cassagrain output antennas 176 which radiate the microwave beam into and through the second set of waveguides 140. A second set of mirrors 158 positioned in the second set of waveguides 140 reflects and directs the beam into and through the second set of radomes 148 into the atmosphere directly rearward of the trailing edges 150. The emission of the radiation beam from the trailing edges 150 is accomplished using structures

which are identical to and function the same as correspondingly numbered components described above with respect to embodiment 10. The radiation beam is radiated through the second set of waveguides 140 onto a second set of mirrors 158, located at approximately midwing, which direct the beam rearwardly into an inverse cassagrain antenna 136 which emits the radiation beam into and through the second set of radomes 148 outwardly and rearwardly into the atmosphere rearward of the trailing edges 150. As with the corresponding structures of embodiment 10, the second set of radomes 148 at the trailing edges 150 are wider than the first set of radomes 144 at the leading edge and consequently a larger region of aft wing heats the air leaving the wing's surface.

A portion of the microwave beam transmitted through the second set of waveguides 140 is directed onto a third set of mirrors 160 located in the fuselage 152 which reflect the beam toward a fourth set of radomes 162 located at the vertical leading edge 164 of the tail stabilizer 166. As with the correspondingly numbered components of embodiment 10, the third set of mirrors 160 reflects the beam rearwardly through the waveguide 140 and the fuselage 152 to another of the third set of mirrors 160 located proximal the tail stabilizer 166 which reflects the beam into and through the fourth set of radomes 162 and outwardly into the atmosphere directly in front of the tail stabilizer 166 and leading edge 164 thereof and generally parallel to the leading edge 164.

The output of the pulse gyrotron 119 is fed to a third set of the cassagrain antennas 178 which radiate it into and through the third set of waveguides 142 and through the third set of radomes 154 into the atmosphere directly in front of the front portion 130 of the fuselage 152. The components utilized to accomplish this emission of radiation from the front portion 130 of the fuselage are structurally and functionally identical to the correspondingly numbered components of embodiment 10. As shown in FIG. 17 and more generally in FIGS. 7A and 7B, a fourth set of mirrors 168 located in the fuselage and at a bend in the third set of waveguides 142 reflects the beam forwardly through the fuselage 152 into one of the inverse cassagrain antennas 136 which emits a preferably pulsed broadened beam of radiation into and through the third set of radomes 154. There is also a seventh mirror or set of mirrors 170 mounted in the fuselage 152 which receives, reflects and directs a portion of the pulsed radiation beam transmitted through the fuselage 152 into and through the first set of radomes 144 and outwardly into the atmosphere directly in front of the wing's 124 leading edge 146.

The cassagrain antennas 32, 132, 76, 176, 78 and 178 include a cassagrain primary aperture which is approximately thirteen centimeters in diameter in order to provide a radiation beam the rays of which are divergent at an angle of approximately 2.5 degrees. This divergence is required because the air heated to 1800 degrees Centigrade expands to encompass a nineteen degree sector at six meters thereby forming a plus or minus one meter high column of heated air for the wing to pass through. This beam is transmitted through the appropriate sets of waveguides 38, 40 and 42 where it gradually expands as it passes therethrough. The inverse cassagrain antennas 36 and 136 include a cassagrain primary aperture which collects the radiation transmitted through the appropriate waveguide and reflects it through a smaller aperture. This effectively broadens the beam so that the rays thereof diverge from each other at an angle of approximately nineteen degrees in order to heat a region of air two meters wide six meters in front of the aircraft. As set forth in the calculations, the primary aperture is approxi-

mately in excess of thirteen centimeters in diameter while the secondary aperture is approximately 1.7 centimeters in diameter. However, the particular sizing of these components depends on the physical design of the aircraft, its flight envelope, etc. and will thus vary in accordance with the particular application.

FIG. 2 shows the orientation of the magnetic field produced by the subsystem 180. As with embodiment 10, the lines of force 194 are oriented so that they are generally perpendicular to the direction of flow 192 of the ions 182 and 184 over the upper and lower surfaces 186 and 188. The magnetic field and lines of force 194 thereof are also oriented so that the interaction of the lines of force 194 with the charged molecules or particles 182 and 184 produces a force acting thereon which propels them in a direction perpendicular to the outer surfaces 174 and perpendicular to the lines of force 194. The ions 182 and 184 flowing over the upper surfaces 186 interact with the lines of force 194 so that the positive ions 182 are propelled vertically away from the upper surfaces 186 by the force 187 acting thereon while the negative ions 184 are propelled vertically toward the upper surfaces 186 by the force 189 acting thereon.

The magnetic field subsystem 180 preferably utilizes a set of coiled wires 196 preferably mounted in the wings 124 preferably at the upper and lower portions thereof, as shown in FIGS. 18 and 19A. The sets of coiled wires 196 are fed electrical current via current distributors 195. The set of coiled wires 196 are preferably wound horizontally around the core or center of each wing 124 so that the coils of each set 196 lie in the same plane and have the same approximate center and are located at the periphery of the wing forming preferably a triangular configuration. Each set of coiled wires thus produces an electromagnet which is vertically oriented so that its poles are in vertical alignment. The set of coiled wires 196 thus produce a magnetic field whose lines of force 194 extend laterally over the upper and lower surfaces 186 and 188 of the wings 24, as illustrated in FIG. 2. The magnetic flux density vectors 197 of the generated magnetic field point toward the fuselage 152 on one side thereof and point away from the fuselage 152 on the other side thereof. The lines of force 194 are thus identical to those of embodiment 10 and produce the same results.

The negatively charged ions 184 are directed toward and onto the outer surfaces 174 of the wing 124 (as well as the fuselage, tail, etc.). The electrons 184 collecting on these outer surfaces 174 will be conducted all over the exposed surface of the aircraft and attach themselves to air molecules adhering to these surfaces thereby transferring a negative charge to these air molecules and result in drawing these molecules adhering to these surfaces off and away from the surfaces 174 thereby reducing viscous drag.

In order to extract and utilize the current flow in the conducting surfaces of the wings 124, the panels 198 (shown in FIG. 19A) of the upper outer surfaces 186 have to be electrically isolated from the lower outer surfaces 188 in order to prevent merging and neutralization of these currents at the trailing edges 150 of the wing 124 via insulator panels 190. Ion collector plates 199 are also provided and positioned directly underneath the panels 198 of the upper surfaces 186 and directly above the panels 198 of the lower surfaces 188 in order to collect the electrical current flowing through surfaces 186 and 188. A set of electrical wires 191 connected to the ion collector plates 199 receive the electrical current therefrom and allow it to be used to provide electrical power to other subsystems and electrical units of the aircraft 120.

FIG. 19B shows the magnetic slabs or plates 193 positioned inside and above the lower surface 188 of the wing

124 aft of the radome 144 (where heating effects might continue) and also positioned inside and below the upper surface 186 and inside and below the lower surface 188 but proximal to the trailing edge 150 of the wing 124. The magnetic plates 193 are preferably shaped to provide a laterally elongated magnetic field the lines of force 194 of which are generally parallel to the upper and lower surfaces 186 and 188 and thereby provide the desired force propelling the ions 182 and 184 in the desired directions, as described hereinabove with regard to embodiment 10. Although the panels 198 of the lower surfaces 188 which are under the magnetic plates 193 are electrically isolated, they are electrically connected to the panels 198 of the upper surfaces 186 which are above the magnetic plates 193 in order to merge the electron flow therein which is received by the set of electrical wires 191. Magnetic plates 193 are also preferably placed in the fuselage just behind the tip 130 thereof (where there is likely to be a high concentration of heat) to provide lines of force which are also oriented perpendicular to the direction of flow 192 of the ions 182 and 184. The magnetic plates 193 proximal the trailing edge 150 of the wing 124 direct the energized ions away from the bottom of the wing 124 but attract the (highly diluted and de-energized) ions to the trailing edge 150 of the upper surface 186. At the upper surface 186 the negatively charged ions 184 are attracted to the positively charged ions 182 in the fluid medium above the upper surface 186 of the wing 124 and will draw the ions viscously adhering to the outer surface 174 off and away. Thus, utilization of magnetic plates 193 in conjunction with the electromagnet producing sets of coiled wires 196 further enhances reduction of viscous drag on the outer surfaces 174 of the aircraft 120.

The set of coiled wires 196 have aft portions 185 located in front of the magnetic slabs 193 and extending in a zig-zag configuration proximal to and along the trailing edge 150 of the wing 124. The aft portions 185 are thus skewed (or angled) relative to the direction of ion flow across the outer surface 174, as shown in FIG. 18. This orientation of the aft portions 185 produces a magnetic field orientation which is angled relative to the direction of ion flow in order to draw diluted and de-energized ions to the collector plates 199.

Accordingly, there has been provided, in accordance with the invention, a system for increasing the aerodynamic efficiency of a vehicle in motion that fully satisfies the objectives set forth above. Although the invention has been described in regard to increasing the aerodynamic efficiency of an aircraft in flight, the system of the invention may also be applied to other types of vehicles or bodies in motion through other types of fluid media. It is to be understood that all terms used herein are descriptive rather than limiting. Although the invention has been described in conjunction with the specific embodiments set forth above, many alternative embodiments, modifications and variations will be apparent to those skilled in the art in light of the disclosure set forth herein. Accordingly, it is intended to include all such alternatives, embodiments, modifications and variations that fall within the spirit and scope of the invention set forth in the claims hereinbelow.

What is claimed is:

1. A system for increasing the dynamic efficiency of a vehicle in a fluid medium, comprising:
a source of electromagnetic radiation;
means for transmitting electromagnetic radiation from said source to desired surface portions of the vehicle, said surface portions including leading edges, said means for transmitting receiving the radiation from said source;

means for emitting a beam of the radiation outwardly and away from the desired surface portions, the leading edges and the vehicle in order to heat the fluid medium thereby reducing mass density of the fluid medium to reduce dynamic drag on the vehicle, said means for emitting receiving the radiation from said means for transmitting, said desired surface portions adjacent to areas of the fluid medium heated by the radiation;

means for producing a magnetic field proximal to the vehicle in order to provide a force for propelling molecules of the fluid medium in a direction generally perpendicular to the vehicle.

2. The system of claim 1 wherein frequency of the radiation is approximately a harmonic resonance frequency of electromagnetic excitation of molecules of the fluid to maximize heating thereof.

3. The system of claim 2 wherein the frequency is approximately sixty Gigahertz.

4. The system of claim 1 wherein said source of radiation includes a pulsed gyrotron to allow radar to be used on the vehicle and a continuous wave gyrotron, said pulsed and continuous wave gyrotrons located at engine of the vehicle and positioned for heat exchange between engine induction and exhaust flow and said gyrotron in order to enhance energy efficiency thereof, said pulsed and continuous wave gyrotrons producing ionization of the molecules of the fluid medium.

5. The system of claim 1 wherein said means for transmitting includes a set of waveguides interconnecting said source and the desired surface portions.

6. The system of claim 5 wherein said means for emitting includes an inverse cassagrain antenna for receiving radiation transmitted through said set of waveguides and emitting the radiation through the surface portions and into the fluid medium.

7. The system of claim 1 wherein said means for transmitting includes a mirror for deflecting and directing the beam to the desired surface portions.

8. The system of claim 1 wherein said means for transmitting, said means for emitting and said source are mounted within the vehicle.

9. The system of claim 1 wherein said source has sufficient power to provide the radiation at an energy density sufficient to heat the fluid medium to a temperature of approximately 1800 degrees Centigrade.

10. The system of claim 5 wherein said means for transmitting includes an output cassagrain antenna for directing a first portion of the radiation from said source into said waveguide and a second portion of the radiation from said source into a portion of the fluid medium proximal to the vehicle.

11. The system of claim 10 wherein said output antenna is connected to an outer surface of the vehicle for transmission of the radiation through the outer surface in order to heat an area of the fluid medium adjacent thereto.

12. The system of claim 1 wherein said means for producing includes:

a source of electrical current;

a set of coiled wires connected to said source and mounted in the vehicle, each of said set of coiled wires oriented and current flow therein directed to produce lines of force of the magnetic field oriented to propel the molecules of the fluid medium in a direction perpendicular to desired surfaces of the vehicle.

13. The system of claim 12 wherein said set of coiled wires are configured into loops.

14. The system of claim 1 wherein said means for producing includes a set of magnets mounted in said vehicle.

each of said set of magnets oriented to produce lines of force of the magnetic field oriented to propel the molecules of the fluid medium in a direction perpendicular to desired surfaces of the vehicle.

15. The system of claim 1 further including:

a means for collecting electron flow on surface portions of the vehicle;

a set of electrical wires connected to said means for collecting for receiving the electron flow therefrom in order to provide a flow of electrical current.

16. The system of claim 15 wherein said means for collecting includes a set of ion collector plates mounted adjacent the surfaces of the vehicle and insulated at edges thereof to prevent crossing over of the electron flow between vehicle surface portions in order to prevent neutralization of the electron flow.

17. The system of claim 1 wherein desired surface portions of the vehicle are composed of a material which is permeable to lines of force of the magnetic field.

18. A system for increasing the dynamic efficiency of a vehicle moving in a fluid medium, comprising:

a source of microwave electromagnetic radiation at a selected frequency of at least fifty Gigahertz;

means for transmitting said millimeter wavelength electromagnetic radiation from said source to desired surface portions of the vehicle, said means for transmitting receiving the radiation from said source;

means for emitting a beam of the radiation outwardly from the desired surface portions in order to heat and ionize the fluid medium thereby reducing mass density of the fluid medium to reduce dynamic drag on the vehicle, said means for emitting receiving the radiation from said means for transmitting;

means for producing a magnetic field proximal to the vehicle in order to provide a force for propelling ionized molecules of the fluid medium away from the vehicle.

19. The system of claim 18 wherein the radiation is at a frequency of approximately sixty Gigahertz for producing harmonic resonance electromagnetic excitation of oxygen molecules of the fluid medium to maximize heating thereof.

20. The system of claim 18 wherein said source of radiation includes a pulsed gyrotron to allow radar to be used in the vehicle and a continuous wave gyrotron, said pulsed and continuous wave gyrotrons located at engine of the vehicle and positioned for heat exchange between engine induction and exhaust flow and said gyrotron in order to enhance efficiency thereof.

21. The system of claim 18 wherein said means for transmitting includes a waveguide interconnecting said source and at least one of the desired surface portions.

22. The system of claim 18 wherein said means for emitting includes an inverse cassagrain antenna for receiving radiation transmitted through said means for transmitting and emitting the radiation through said at least one of the surface portions and into the fluid medium, said cassagrain antenna including a primary reflector having an aperture and a secondary reflector small relative to the primary reflector, said primary and secondary reflectors positioned so that the radiation is radiated through the aperture and reflected off the secondary reflector back into said primary reflector where it is reradiated into the fluid medium in a narrow beam the rays of which are divergent at an angle of approximately nineteen degrees.

23. The system of claim 18 wherein said means for transmitting includes a waveguide for propagating the radia-

tion and a mirror mounted in said waveguide for deflecting and directing the beam to at least one of the desired surface portions without scattering thereof.

24. The system of claim 18 wherein said means for transmitting, said means for emitting and said source are mounted within the vehicle.

25. The system of claim 18 wherein said source has sufficient power to provide the radiation at a power density sufficient to continually heat the fluid to a temperature of approximately 1800 degrees Centigrade.

26. A system for increasing the dynamic efficiency of a vehicle moving in a fluid medium, comprising:

a source of electromagnetic radiation;

means for transmitting electromagnetic radiation from said source to desired surface portions of the vehicle, said means for transmitting receiving the radiation from said source;

means for emitting a beam of the radiation outwardly and away from the desired surface portions and away from the vehicle into the fluid medium so that the fluid medium absorbs substantially all the electromagnetic radiation energy thereof in order to heat the fluid medium thereby reducing mass density of the fluid medium to reduce dynamic drag on the vehicle, said means for emitting receiving the radiation from said means for transmitting, said surface portions adjacent to areas of the fluid medium heated by the radiation;

means for producing a magnetic field proximal to the vehicle in order to provide a force for propelling molecules of the fluid medium away from the vehicle.

27. A system for increasing the dynamic efficiency of a vehicle moving in a fluid medium, comprising:

a source of electromagnetic radiation at a frequency of approximately sixty Gigahertz;

means for transmitting electromagnetic radiation at the frequency of sixty Gigahertz from said source to desired surface portions of the vehicle, said means for transmitting receiving the radiation from said source;

means for emitting a beam of the radiation outwardly from the desired surface portions into the fluid medium in order to heat the fluid medium thereby reducing mass density of the fluid medium to reduce dynamic drag on the vehicle, said means for emitting receiving the radiation from said means for transmitting;

means for producing a magnetic field proximal to the vehicle in order to provide a force for propelling molecules of the fluid medium away from the vehicle.

28. A system for increasing the aerodynamic efficiency of an aircraft in flight and reducing the incidence and intensity of shock waves produced by the aircraft when flying at supersonic velocities, comprising:

a continuous wave gyrotron located in a jet engine of the aircraft and positioned for heat exchange between exhaust and intake flows of the engine and said gyrotron for enhanced energy efficiency thereof;

a pulsed gyrotron located in the jet engine of the aircraft and positioned for heat exchange between intake and exhaust flows of the engine and said pulsed gyrotron for enhanced energy efficiency thereof;

means for emitting a beam of the radiation outwardly from desired surface portions of the aircraft into the desired portions of the atmosphere proximal to the aircraft in order to heat the desired portions of the atmosphere thereby reducing mass density thereof to reduce dynamic drag on the aircraft, said means for

25

emitting receiving the radiation from said continuous wave gyrotron and from said pulsed gyrotron;

means for producing a magnetic field proximal to the aircraft in order to provide a force for propelling molecules of the atmosphere away from the aircraft.

29. A system for increasing the dynamic efficiency of a vehicle moving in a fluid medium, comprising:

a source of millimeter wavelength electromagnetic radiation;

means for transmitting said millimeter wavelength electromagnetic radiation from said source to desired surface portions of the vehicle, said means for transmitting receiving the radiation from said source;

means for emitting a beam of the radiation outwardly and away from the desired surface portions in order to heat

5

10

26

the fluid medium thereby reducing mass density of the fluid medium to reduce dynamic drag on the vehicle, said means for emitting receiving the radiation from said means for transmitting;

means for producing a magnetic field proximal to the vehicle in order to provide a force for propelling ionized molecules of the fluid medium away from the vehicle, the magnetic field having lines of force oriented generally perpendicular to the direction of ion flow over the desired surface portions and to the direction of motion of the vehicle relative to the fluid medium.

* * * * *

CASE #555[Direct PDF Download](#)

SOURCE URL

<https://patentimages.storage.googleapis.com/08/da/1c/e8d763bcd38db0/US5797563.pdf>

DOMAIN

patentimages.storage.googleapis.com

CASE ID

#555 of 924

CONTEXT FROM ORIGINAL DOCUMENT

nt djvu.txt

(PUBLIC DOMAIN) - 22 August 1998 — Ret. Lt. Col. Ron Blackburn of Lockheed Martin Skunk

Works and co-founder of the ATP Group at BDM Intl. is awarded a patent for technology that increases aerodynamic and hydrodynamic efficiency of a vehicle in motion that includes sketches of a disc. Several years earlier, Blackburn states on a podcast he reverse engineered the capability to eliminate sonic booms at high speeds by using videos of disc-shaped craft he had access to.

•